

REV.	DATE	DESCRIPTION
A	01/04/04	UPDATE DRAWING FORMAT

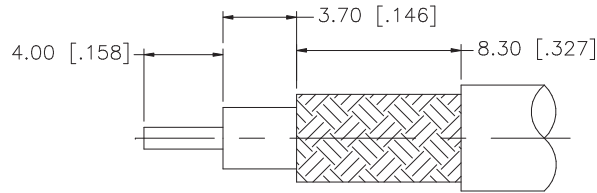

RECOMMENDED
CABLE STRIPPING DIM'S

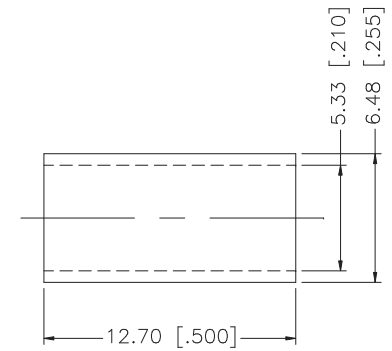
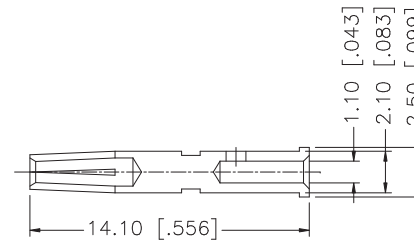
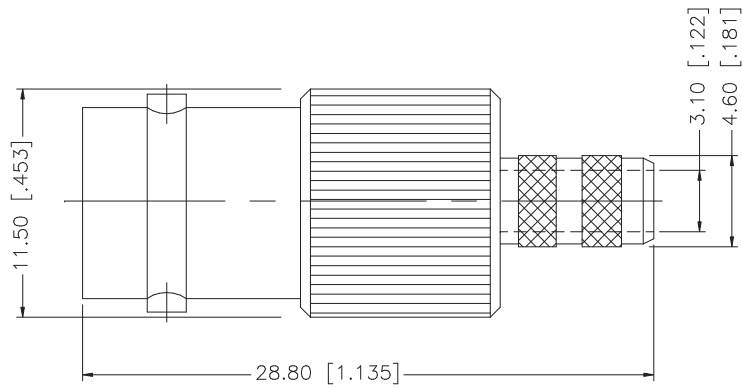

NOTE:

1. CRIMPED FERRULE
HEX CRIMP SIZE .213"
2. CRIMPED CONTACT PIN
HEX CRIMP SIZE .068"

8					<p>UNLESS OTHERWISE SPECIFIED DIMENSIONS ARE IN MILLIMETERS. DIMENSIONS IN [] ARE IN INCHES AND FOR CUSTOMER REFERENCE ONLY.</p> <p>UNLESS OTHERWISE SPECIFIED TOLERANCES FOR MILLIMETERS ARE: 0.5 - 8mm ± 0.20mm 8 - 30mm ± 0.40mm 30 - 120mm ± 0.50mm</p> <p>UNLESS OTHERWISE SPECIFIED TOLERANCES FOR INCHES ARE: .020 - .315 = ± 0.007" .315 - 1.180 = ± 0.015" 1.180 - 4.724 = ± 0.020"</p> <p>DO NOT SCALE DRAWING</p>	APPROVALS	DATE	<h1 style="text-align: center;">Amphenol Connex</h1>			
7				DRAWN		G.R.S.	01/04/04				
6				CHECKED				PART DESCRIPTION <h2 style="text-align: center;">BNC CRIMP JACK</h2> <p style="text-align: center;">(FOR RG-58C/U CABLE) 50 ohms</p>			
5				ISSUED							
4	FERRULE	COPPER	NICKEL	1		SHEET	1 OF 1	PART NO. <h2 style="text-align: center;">112144</h2>			
3	CONTACT PIN	PHOS. BRONZE	GOLD	1							
2	INSULATOR	TEFLON	NATURAL	1				DWG. NO. 112144.DWG			
1	HOUSING/BODY	BRASS	NICKEL	1							
	DESCRIPTION	MATERIAL	FINISH	QTY	CAD FILE	C:/112/112144.DWG	REV. A	SIZE A	SCALE NA		