

REV.	DATE	DESCRIPTION
A	01/28/03	REVISE BODY DIMENSIONS
B	04/29/04	REMOVED CENTER CONTACT PIN
C	12/30/04	MODIFY BARREL I.D. TO 1.7mm

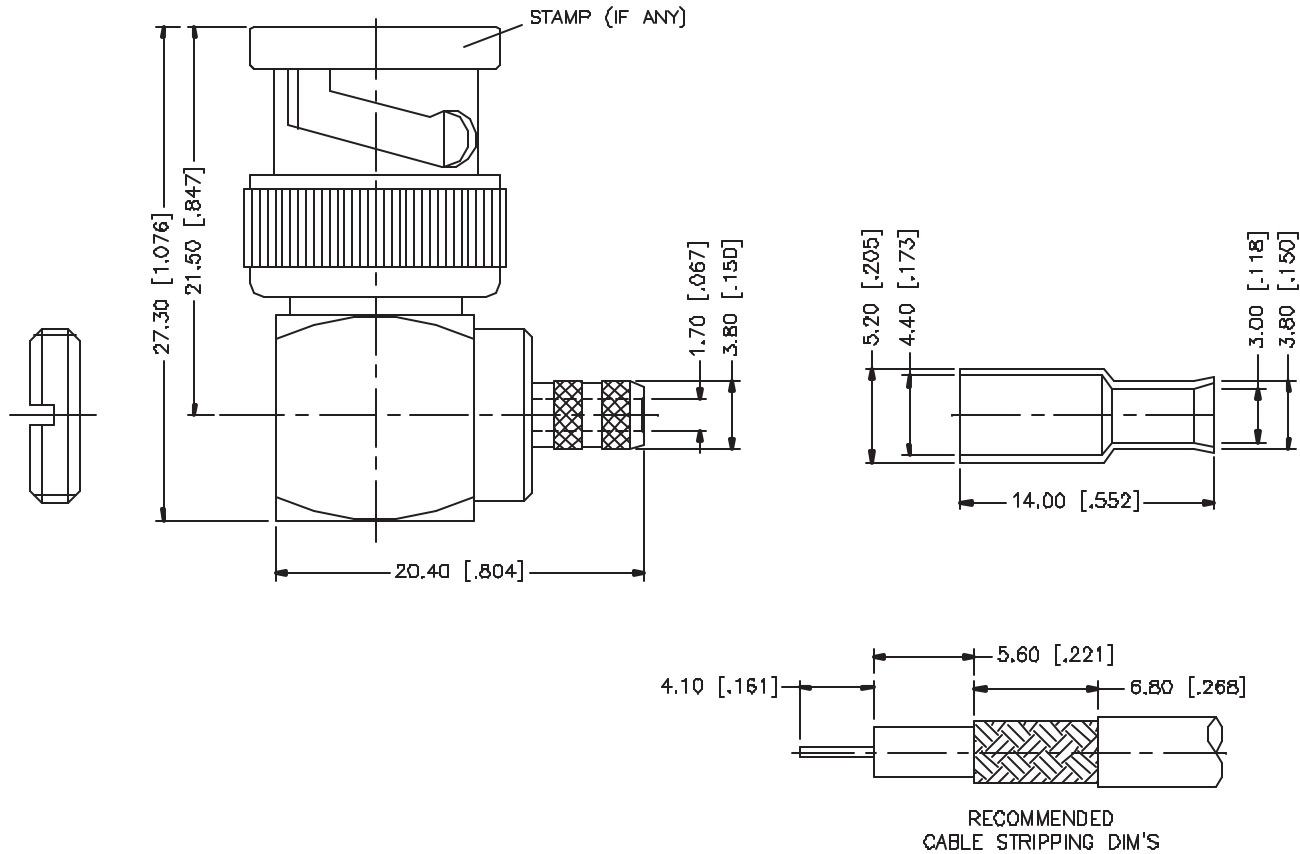

REV.	DESCRIPTION	MATERIAL	FINISH	QTY	UNLESS OTHERWISE SPECIFIED DIMENSIONS ARE IN MILLIMETERS. DIMENSIONS IN [] ARE IN INCHES AND FOR CUSTOMER REFERENCE ONLY.	APPROVALS	DATE	Amphenol Connex										
8					UNLESS OTHERWISE SPECIFIED TOLERANCES FOR MILLIMETERS ARE: 0.5 - 8mm ± 0.20mm 8 - 30mm ± 0.40mm 30 - 120mm ± 0.50mm UNLESS OTHERWISE SPECIFIED TOLERANCES FOR INCHES ARE: .020 - .315 = ± 0.007" .315 - 1.180 = ± 0.015" 1.180 - 4.724 = ± 0.020" DO NOT SCALE DRAWING	DRAWN	G.R.S.	12/30/04	Part Description BNC R/A CRIMP PLUG - 75ohm (FOR RG-179 /U, 187A/U CABLE)									
7				CHECKED				Part No. 112179										
6				5		NUT	BRASS					NICKEL	1	ISSUED				
4	FERRULE	COPPER	NICKEL	1		3	CONTACT PIN	BRASS	GOLD	1	SHEET	1 OF 1						
2	INSULATOR	DELTRIN	NATURAL	1		1	INSULATOR	DELTRIN	NATURAL	1								
1	SHELL/BODY	BRASS	NICKEL	1	1	SHELL/BODY	BRASS	NICKEL	1									
DESCRIPTION					MATERIAL	FINISH	QTY	CAD FILE		C:/112/112179.DWG	DWG. NO.	112179.DWG	REV.	C	SIZE	A	SCALE	NA