

REV.	DATE	DESCRIPTION
NC	09/14/95	INITIAL RELEASE
A	05/10/05	UPDATE DRAWING FORMAT
B	07/25/05	EXPLODE TO SHOW ALL PARTS/ MODIFY DESCRIPTION

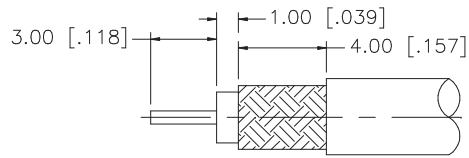

RECOMMENDED  
CABLE STRIPPING DIM'S

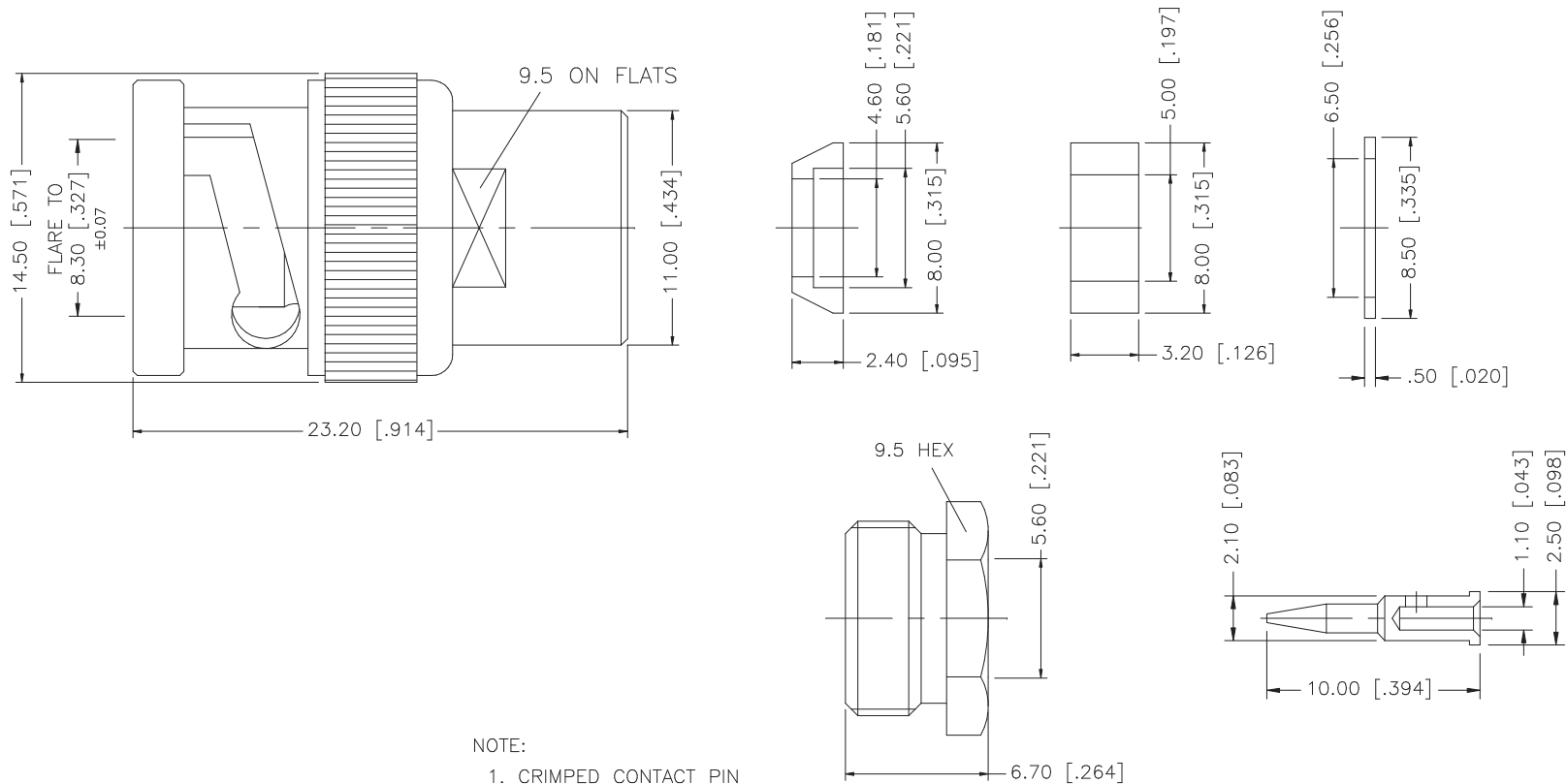

NOTE:  
1. CRIMPED CONTACT PIN  
HEX CRIMP SIZE .068"

DESCRIPTION	MATERIAL	FINISH	QTY	DO NOT SCALE DRAWING	APPROVALS	DATE	Amphenol Connex				
8				UNLESS OTHERWISE SPECIFIED DIMENSIONS ARE IN MILLIMETERS. DIMENSIONS IN [ ] ARE IN INCHES AND FOR CUSTOMER REFERENCE ONLY.			PART DESCRIPTION <b>BNC CLAMP PLUG</b> (FOR RG-58C/U, 58/U, 142A/U, 223/U)				
7	CONTACT PIN	BRASS	GOLD	1	DRAWN	G.R.S.					07/25/04
6	HEX NUT	BRASS	NICKEL	1	UNLESS OTHERWISE SPECIFIED TOLERANCES FOR MILLIMETERS ARE: 0.5 - 8mm ± 0.20mm 8 - 30mm ± 0.40mm 30 - 120mm ± 0.50mm	CHECKED		DWG. NO. 112348.DWG			
5	WASHER	BRASS	NICKEL	1	UNLESS OTHERWISE SPECIFIED TOLERANCES FOR INCHES ARE: .020 - .315 = ± 0.007" .315 - 1.180 = ± 0.015" 1.180 - 4.724 = ± 0.020"	ISSUED		REV. B			
4	GASKET	SILICONE	RED	1		SHEET	1 OF 1	SIZE A			
3	TOP HAT	BRASS	NICKEL	1		CAD FILE	C:/112/112348.DWG	SCALE NA			
2	INSULATOR	DELTRIN	NATURAL	1							
1	BODY	BRASS	NICKEL	1							