

REV.	DATE	DESCRIPTION
NC	08/18/98	INITIAL RELEASE
A	07/25/05	UPDATE DRAWING FORMAT

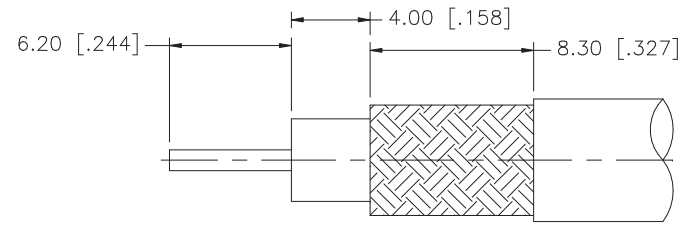
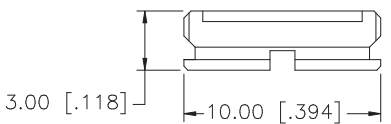
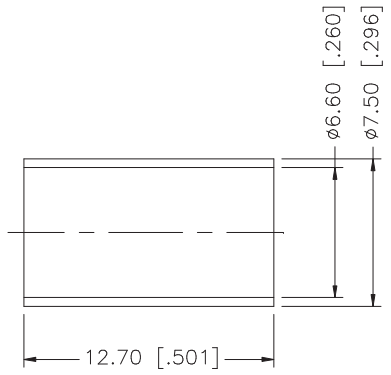
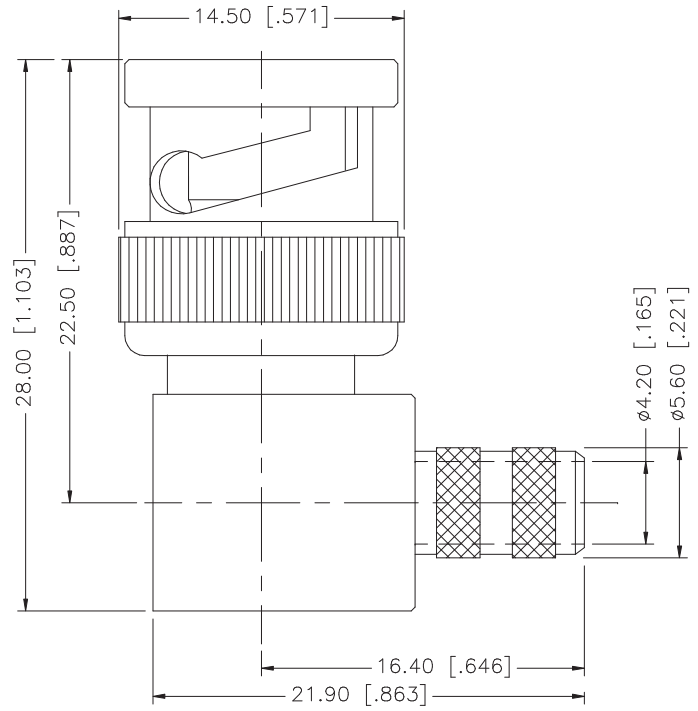

RECOMMENDED  
CABLE STRIPPING DIM'S

8				
7				
6				
5	COVER	BRASS	NICKEL	1
4	FERRULE	COPPER	NICKEL	1
3	CONTACT PIN	BRASS	GOLD	1
2	INSULATOR	DELTRIN	NATURAL	1
1	BODY	BRASS	NICKEL	1
	DESCRIPTION	MATERIAL	FINISH	QTY

UNLESS OTHERWISE SPECIFIED DIMENSIONS ARE IN MILLIMETERS. DIMENSIONS IN [ ] ARE IN INCHES AND FOR CUSTOMER REFERENCE ONLY.

UNLESS OTHERWISE SPECIFIED TOLERANCES FOR MILLIMETERS ARE:  
0.5 - 8mm ± 0.20mm  
8 - 30mm ± 0.40mm  
30 - 120mm ± 0.50mm

UNLESS OTHERWISE SPECIFIED TOLERANCES FOR INCHES ARE:  
.020 - .315 = ± 0.007"  
.315 - 1.180 = ± 0.015"  
1.180 - 4.724 = ± 0.020"

DO NOT SCALE DRAWING

APPROVALS	DATE
DRAWN G.R.S.	07/25/05
CHECKED	
ISSUED	
SHEET 1 OF 1	
CAD FILE C:/112/112601.DWG	

**Amphenol Connex**

PART DESCRIPTION  
**BNC R/A CRIMP PLUG - LMR 240 CABLE (RG8X CABLE)**

PART NO. **112601**

DWG. NO. 112601.DWG    REV. A    SIZE A    SCALE NA