

REV.	DATE	DESCRIPTION
NC	01/30/04	INITIAL RELEASE

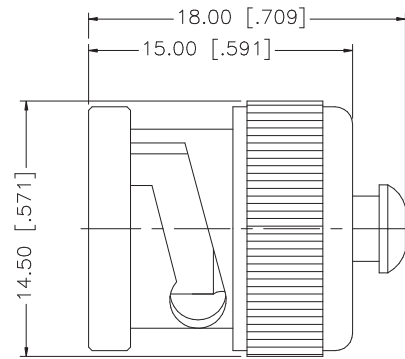

8					UNLESS OTHERWISE SPECIFIED DIMENSIONS ARE IN MILLIMETERS. DIMENSIONS IN [] ARE IN INCHES AND FOR CUSTOMER REFERENCE ONLY.	APPROVALS	DATE	Amphenol Connex				
7						DRAWN	G.R.S.					01/30/04
6					UNLESS OTHERWISE SPECIFIED TOLERANCES FOR MILLIMETERS ARE: 0.5 - 8mm ± 0.20mm 8 - 30mm ± 0.40mm 30 - 120mm ± 0.50mm	CHECKED		PART DESCRIPTION				
5						ISSUED			BNC MALE CAP			
4					UNLESS OTHERWISE SPECIFIED TOLERANCES FOR INCHES ARE: .020 - .315 = ± 0.007" .315 - 1.180 = ± 0.015" 1.180 - 4.724 = ± 0.020"	SHEET	1 OF 1	PART NO.				
3	RIVET	BRASS	NICKEL	1		CAD FILE			202100-10			
2	GASKET	SILICONE	RED	1	DO NOT SCALE DRAWING	C:/202/202100-10.DWG		DWG. NO.	202100-10.DWG	REV. NC	SIZE A	SCALE NA
1	SHELL/BODY	BRASS	NICKEL	1								
	DESCRIPTION	MATERIAL	FINISH	QTY								