

REV.	DATE	DESCRIPTION
NC	09/08/95	INITIAL RELEASE
A	05/01/06	UPDATE DRAWING FORMAT

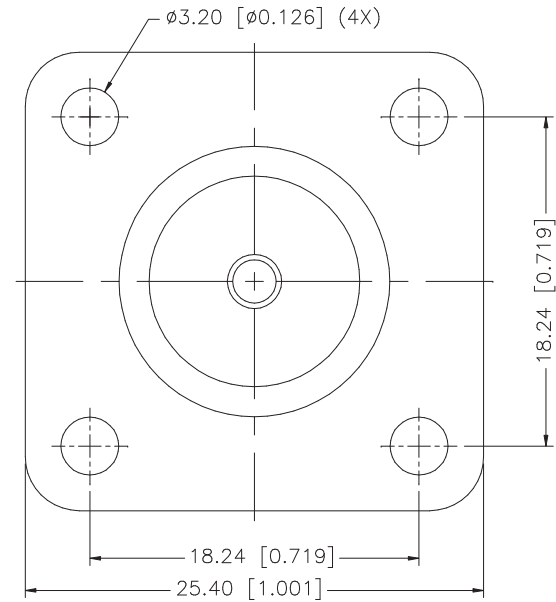
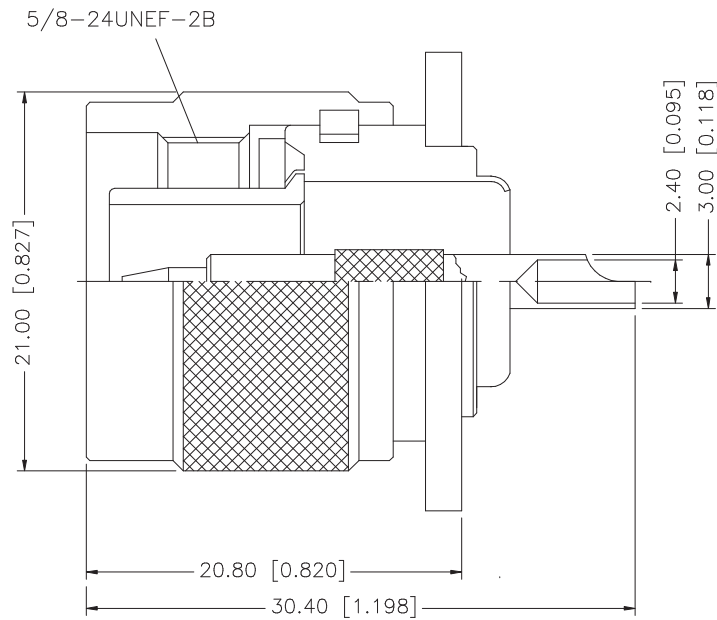

8				
7				
6				
5				
4				
3	CONTACT PIN	BRASS	GOLD	1
2	INSULATOR	TEFLON	NATURAL	1
1	BODY	BRASS	NEXCOTE	1
	DESCRIPTION	MATERIAL	FINISH	QTY

UNLESS OTHERWISE SPECIFIED DIMENSIONS ARE IN MILLIMETERS. DIMENSIONS IN [ ] ARE IN INCHES AND FOR CUSTOMER REFERENCE ONLY.

UNLESS OTHERWISE SPECIFIED TOLERANCES FOR MILLIMETERS ARE:  
0.5 - 8mm ± 0.20mm  
8 - 30mm ± 0.40mm  
30 - 120mm ± 0.50mm

UNLESS OTHERWISE SPECIFIED TOLERANCES FOR INCHES ARE:  
.020 - .315 = ± 0.007"  
.315 - 1.180 = ± 0.015"  
1.180 - 4.724 = ± 0.020"

DO NOT SCALE DRAWING

APPROVALS	DATE
DRAWN G.R.S.	05/01/06
CHECKED	
ISSUED	
SHEET 1 OF 1	
CAD FILE	C:/172/172118.DWG

# Amphenol Connex

PART DESCRIPTION  
N PANEL RECEPTACLE PLUG

PART NO. 172118

DWG. NO. 172118.DWG	REV. A	SIZE A	SCALE NA
---------------------	--------	--------	----------