

REV.	DATE	ECR NO.	DESCRIPTION
NC	07/30/09	XXXXXX	INITIAL RELEASE

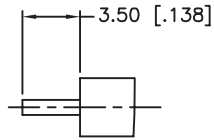

RECOMMENDED  
CABLE STRIPPING DIM'S

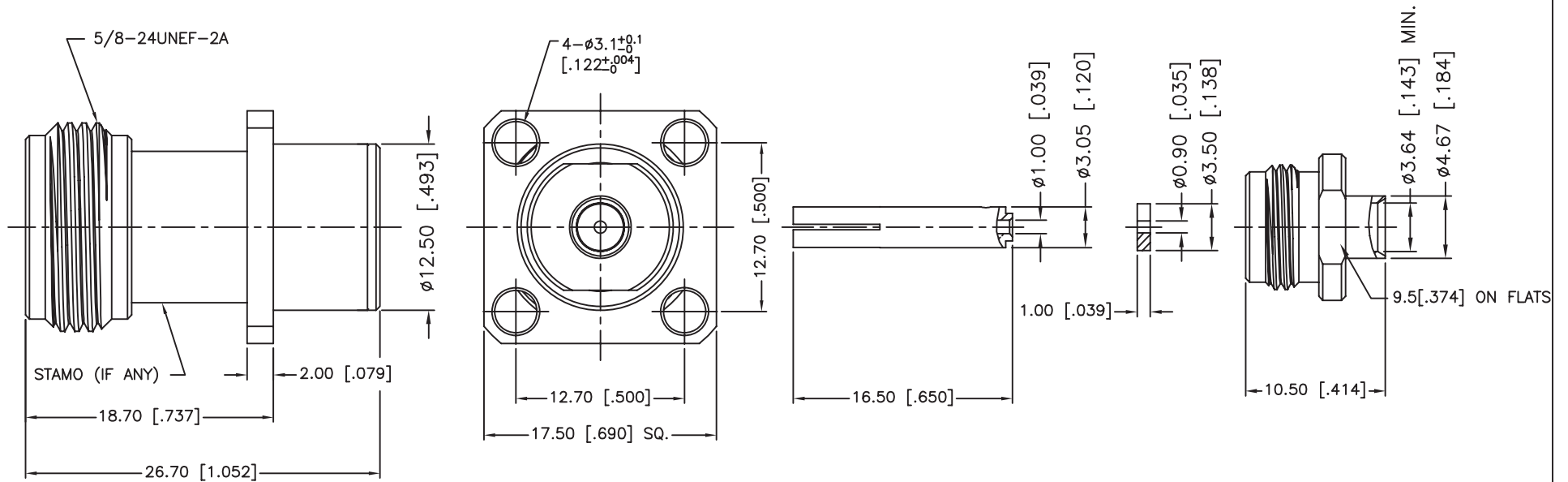

1. CONTACT PIN TO SILDER

6	SOLDER NUT	BRASS	GOLD	1
5	INSULATOR	PTFE	NATURAL	1
4	CONTACT PIN	PHOSPHOR BRONZE	GOLD	1
3	INNER BODY	BRASS	NEXCOTE	1
2	INSULATOR	PTFE	NATURAL	1
1	BODY	BRASS	NEXCOTE	1
DESCRIPTION	MATERIAL	FINISH	QTY	

UNLESS OTHERWISE SPECIFIED DIMENSIONS ARE IN MILLIMETERS. DIMENSIONS IN [ ] ARE IN INCHES AND FOR CUSTOMER REFERENCE ONLY.

UNLESS OTHERWISE SPECIFIED TOLERANCES FOR MILLIMETERS ARE:  
0.5 - 8mm ± 0.20mm  
8 - 30mm ± 0.40mm  
30 - 120mm ± 0.50mm

UNLESS OTHERWISE SPECIFIED TOLERANCES FOR INCHES ARE:  
.020 - .315 = ± 0.007"  
.315 - 1.180 = ± 0.015"  
1.180 - 4.724 = ± 0.020"

DO NOT SCALE DRAWING

APPROVALS	DATE
DRAWN M.ZHANG	07/30/09
CHECKED	
ISSUED	
SHEET 1 OF 1	
CAD FILE C:/CONNEX/172170-10.DWG	

<b>Amphenol Connex</b>			
PART DESCRIPTION			
N PANEL DIRECT SOLDER JACK (FOR .141" CABLE)			
PART NO. 172170-10			
DWG. NO. 172170-10.DWG	REV. NC	SIZE A	SCALE NA