

REV.	DATE	DESCRIPTION
A	02/28/02	MODIFY CONTACT PIN AND BODY LENGTH
B	04/04/03	UPDATE DRAWING FORMAT

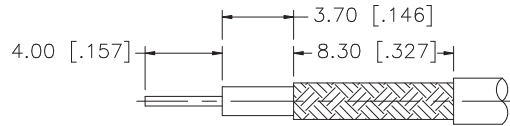

RECOMMENDED
CABLE STRIPPING DIM'S

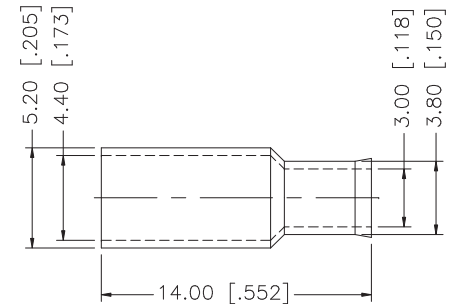
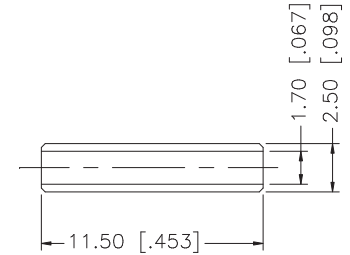
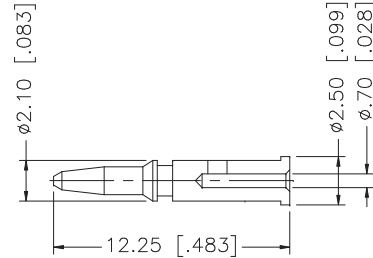
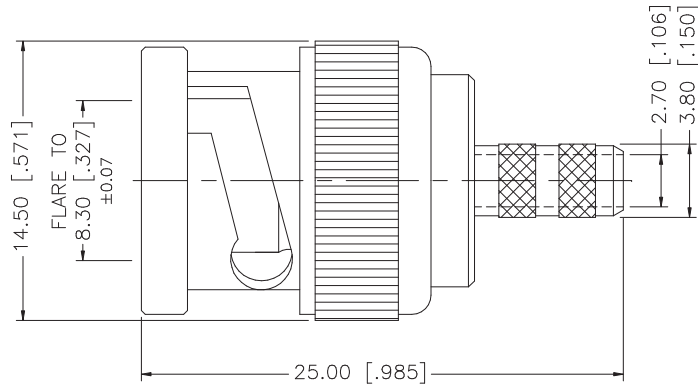

CRIMP NOTES:

1. CRIMPED FERRULE
HEX CRIMP SIZE .178"
2. CRIMPED CONTACT PIN
HEX CRIMP SIZE .068"

8				
7				
6				
5	FERRULE	COPPER	NICKEL	1
4	SLEEVE	DELTRIN	NATURAL	1
3	CONTACT PIN	BRASS	GOLD	1
2	INSULATOR	DELTRIN	NATURAL	1
1	SHELL/BODY	BRASS	NICKEL	1
	DESCRIPTION	MATERIAL	FINISH	QTY

UNLESS OTHERWISE SPECIFIED DIMENSIONS ARE IN MILLIMETERS. DIMENSIONS IN [] ARE IN INCHES AND FOR CUSTOMER REFERENCE ONLY.

UNLESS OTHERWISE SPECIFIED TOLERANCES FOR MILLIMETERS ARE:
0.5 - 8mm ± 0.20mm
8 - 30mm ± 0.40mm
30 - 120mm ± 0.50mm

UNLESS OTHERWISE SPECIFIED TOLERANCES FOR INCHES ARE:
.020 - .315 = ± 0.007"
.315 - 1.180 = ± 0.015"
1.180 - 4.724 = ± 0.020"

DO NOT SCALE DRAWING

APPROVALS	DATE
DRAWN G.R.S.	04/04/03
CHECKED	
ISSUED	
SHEET 1 OF 1	
CAD FILE C:/112/112132.DWG	

Amphenol Connex

PART DESCRIPTION
BNC CRIMP PLUG - 50 ohms
(RG 174/U, 188/U, 316/U CABLE)

PART NO. 112132

DWG. NO.	REV.	SIZE	SCALE
112132.DWG	B	A	NA