

| REV. | DATE     | DESCRIPTION                           |
|------|----------|---------------------------------------|
| D    | 11/08/99 | UPDATE STRIPPING DIM'S                |
| E    | 01/23/03 | REFORMAT DRAWING/ UPDATE FERRULE DIMS |

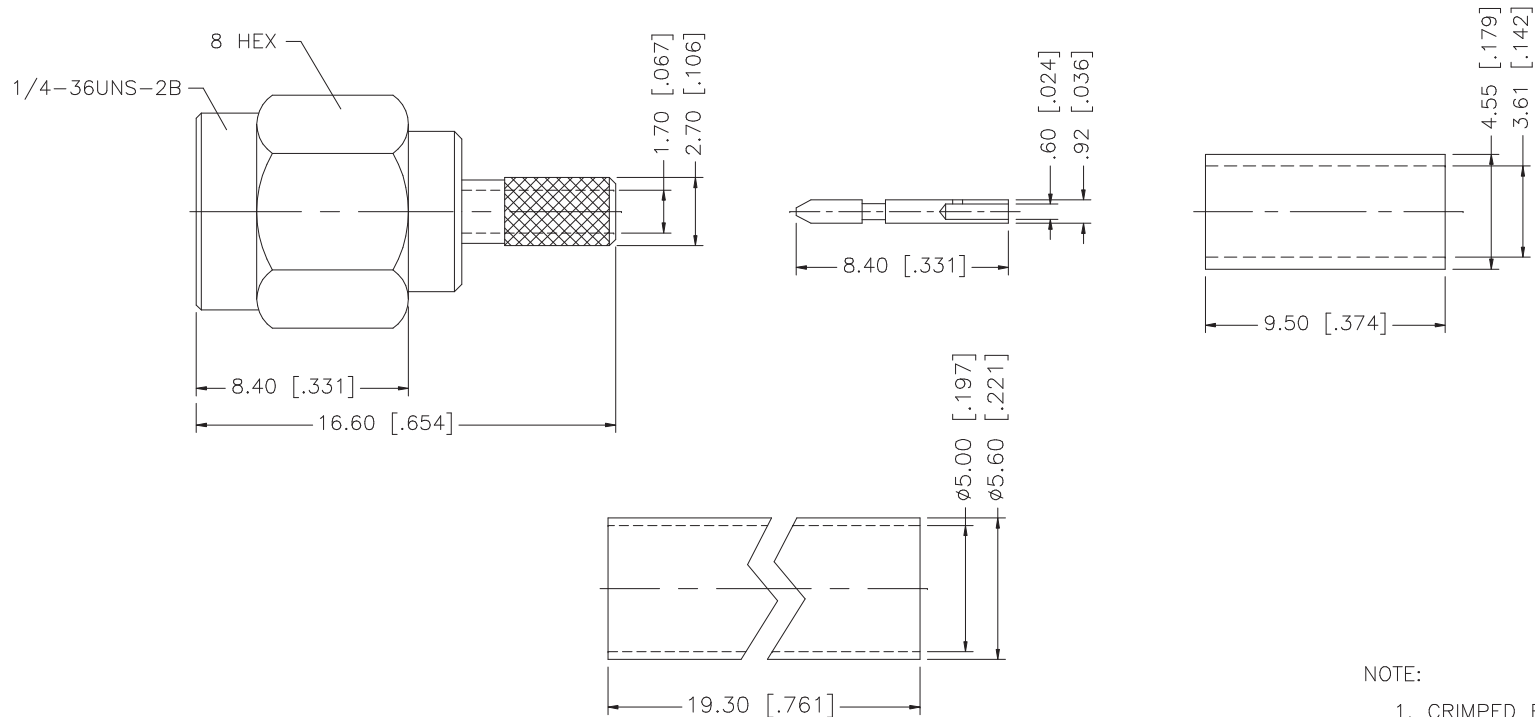
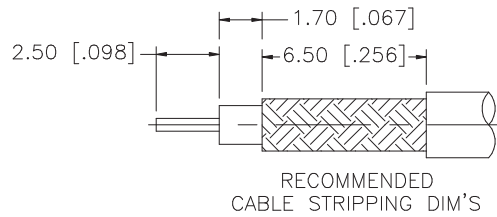

- NOTE:
1. CRIMPED FERRULE  
HEX CRIMP SIZE .151"
  2. CONTACT PIN TO SOLDER

|   |                  |             |         | UNLESS OTHERWISE SPECIFIED DIMENSIONS ARE IN MILLIMETERS. DIMENSIONS IN [ ] ARE IN INCHES AND FOR CUSTOMER REFERENCE ONLY. | APPROVALS  | DATE   | <b>Amphenol Connex</b> |                           |               |                 |          |   |  |
|---|------------------|-------------|---------|--|--|--------|------------------------|---------------------------|---------------|-----------------|----------|---|--|
| 8 |                  |             |         |  | DRAWN  | G.R.S. |                        |                           |               |                 | 01/23/03 | PART DESCRIPTION<br><b>SMA CRIMP PLUG<br/>(FOR RG-316/U DOUBLE BRAID CABLE)</b> |  |
| 7 | HEAT SHRINK TUBE |             |         | 1  | CHECKED  |        |                        | PART NO.<br><b>132178</b> |               |                 |          |   |  |
| 6 | FERRULE          | COPPER      | GOLD    | 1  | ISSUED   |        |                        |                           |               |                 |          | DWG. NO. <b>132178.DWG</b>  |  |
| 5 | CONTACT PIN      | BRASS       | GOLD    | 1  | SHEET  | 1 OF 1 |                        | REV. <b>E</b>             | SIZE <b>A</b> | SCALE <b>NA</b> |          |   |  |
| 4 | GASKET           | SILICONE    | RED     | 1  | CAD FILE<br>C:/132/132178.DWG  |        |                        |                           |               |                 |          |   |  |
| 3 | RETAINER RING    | BER. COPPER | NATURAL | 1  | UNLESS OTHERWISE SPECIFIED TOLERANCES FOR MILLIMETERS ARE:<br>0.5 - 8mm ± 0.20mm<br>8 - 30mm ± 0.40mm<br>30 - 120mm ± 0.50mm           |        |                        |                           |               |                 |          |   |  |
| 2 | INSULATOR        | TEFLON      | NATURAL | 1  | UNLESS OTHERWISE SPECIFIED TOLERANCES FOR INCHES ARE:<br>.020 - .315 = ± 0.007"<br>.315 - 1.180 = ± 0.015"<br>1.180 - 4.724 = ± 0.020" |        |                        |                           |               |                 |          |   |  |
| 1 | SHELL/BODY       | BRASS       | GOLD    | 1  | DO NOT SCALE DRAWING   |        |                        |                           |               |                 |          |   |  |