

REV.	DATE	DESCRIPTION
A	06/25/98	REVISIONS MADE TO CONNECTOR
B	01/27/00	REVISE INSULATOR, CONTACT PIN
C	07/28/06	UPDATE DRAWING FORMAT

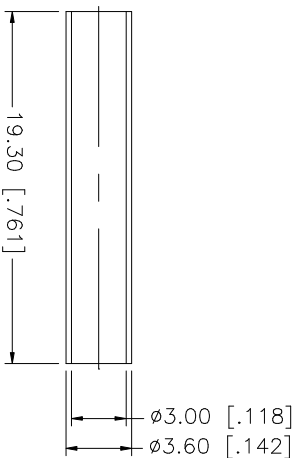
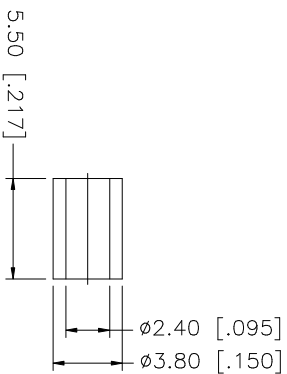
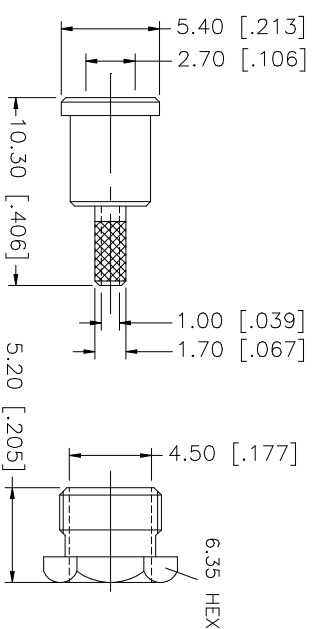
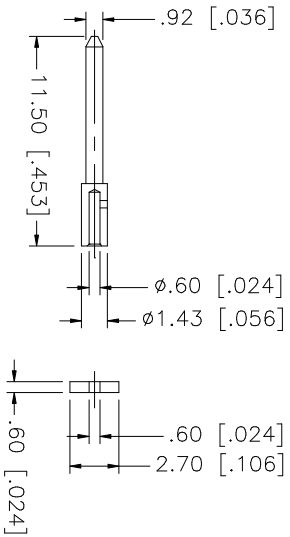
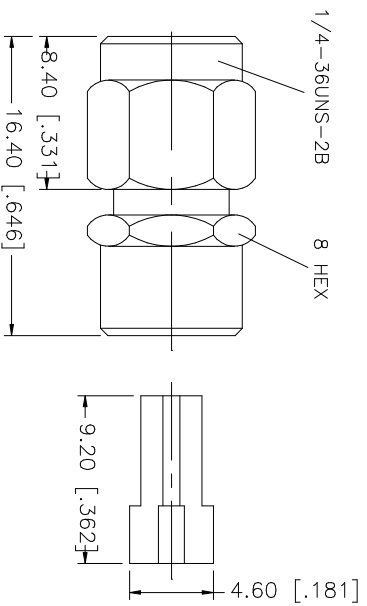
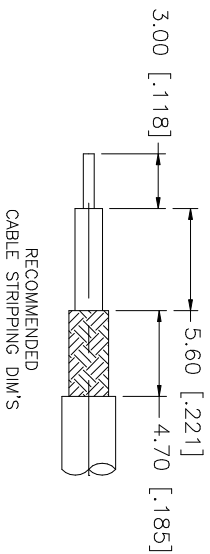

QTY	DESCRIPTION	MATERIAL	FINISH	QTY	DO NOT SCALE DRAWING	APPROVALS	DATE	PART DESCRIPTION
1	HEAT SHRINK							<p style="text-align: center;">Amphenol Connex</p> <p style="text-align: center;">SMA CRIMP PLUG (FOR RG-178B/U, 196A/U, CABLE)</p> <p style="text-align: center;">132193</p>
1	FERRULE	COPPER	GOLD			DRAWN G.R.S.	07/28/06	
1	HEX NUT	BRASS	GOLD			CHECKED		
1	BARREL	BRASS	GOLD			ISSUED		
1	CONTACT PIN	BRASS	GOLD			SHEET 1 OF 1		
1	INSULATOR	TEFLON	NATURAL					
1	BODY	BRASS	GOLD					
	DESCRIPTION	MATERIAL	FINISH	QTY				

UNLESS OTHERWISE SPECIFIED DIMENSIONS ARE IN MILLIMETERS. DIMENSIONS IN [] ARE IN INCHES AND FOR CUSTOMER REFERENCE ONLY.

UNLESS OTHERWISE SPECIFIED TOLERANCES FOR MILLIMETERS ARE:

0.5 - 8mm ± 0.20mm
8 - 30mm ± 0.40mm
30 - 120mm ± 0.50mm

UNLESS OTHERWISE SPECIFIED TOLERANCES FOR INCHES ARE:

.020 - .315 = ± 0.007"
.315 - 1.180 = ± 0.015"
1.180 - 4.724 = ± 0.020"

APPROVALS	DATE
DRAWN G.R.S.	07/28/06
CHECKED	
ISSUED	
SHEET 1 OF 1	

CAD FILE	DWG. NO.	REV.	SIZE	SCALE
C:/132/132193.DWG	132193.DWG	C	A	NA