

REV.	DATE	DESCRIPTION
A	01/25/04	UPDATE DRAWING FORMAT
B	08/07/05	MODIFY CONTACT PIN

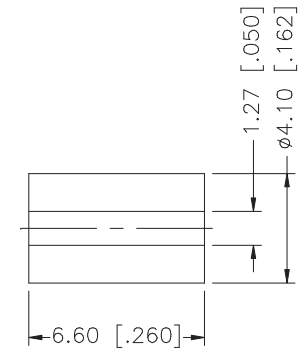
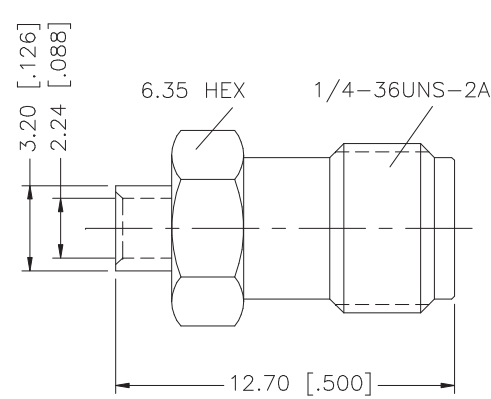
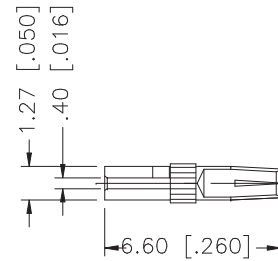
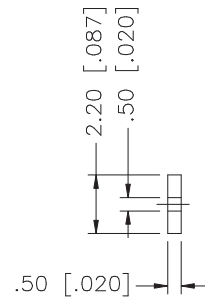
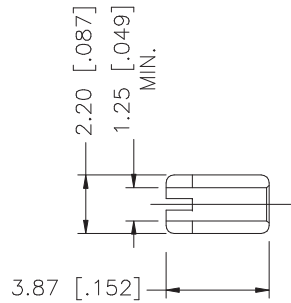
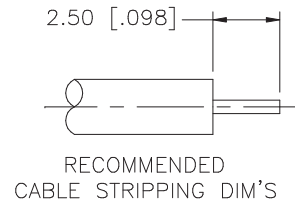

NOTE:

- CONTACT PIN TO SOLDER

DESCRIPTION	MATERIAL	FINISH	QTY	DO NOT SCALE DRAWING	APPROVALS	DATE	Amphenol Connex				
8							PART DESCRIPTION SMA DIRECT SOLDER JACK (FOR .047" SIMI-RIGID CABLE)				
7						PART NO. 132257					
6										DWG. NO. 132257.DWG	
5	SOLDER BARREL	BRASS	GOLD	1	UNLESS OTHERWISE SPECIFIED DIMENSIONS ARE IN MILLIMETERS. DIMENSIONS IN [] ARE IN INCHES AND FOR CUSTOMER REFERENCE ONLY.	DRAWN	G.R.S.	08/07/05	REV. B		
4	INSULATOR	TEFLON	NATURAL	1	UNLESS OTHERWISE SPECIFIED TOLERANCES FOR MILLIMETERS ARE: 0.5 - 8mm ± 0.20mm 8 - 30mm ± 0.40mm 30 - 120mm ± 0.50mm	CHECKED					
3	CONTACT PIN	BER. COPPER	GOLD	1	UNLESS OTHERWISE SPECIFIED TOLERANCES FOR INCHES ARE: .020 - .315 = ± 0.007" .315 - 1.180 = ± 0.015" 1.180 - 4.724 = ± 0.020"	ISSUED					
2	INSULATOR	TEFLON	NATURAL	1		SHEET	1 OF 1				
1	BODY	BRASS	GOLD	1		CAD FILE	C:/132/132257.DWG				