

REV.	DATE	DESCRIPTION
NC	09/22/99	INITIAL RELEASE
A	07/20/05	UPDATE DRAWING FORMAT

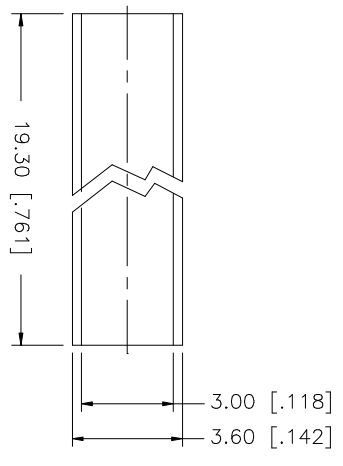
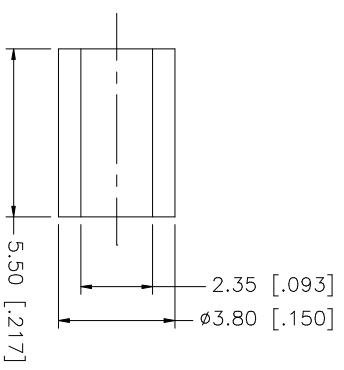
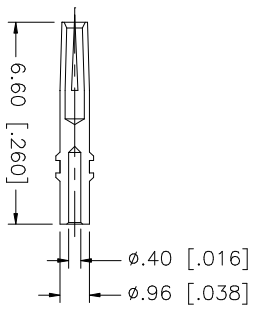
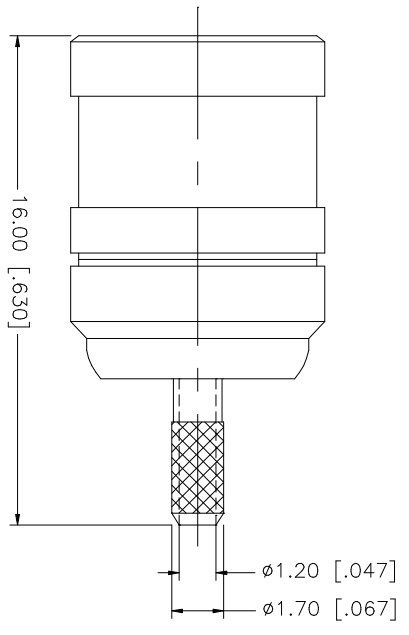
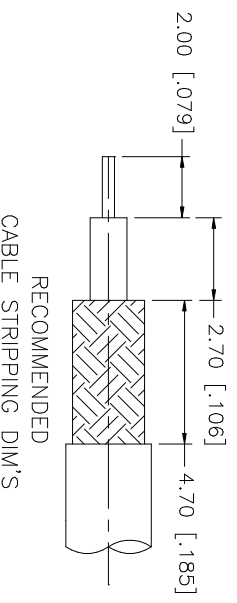

QTY	FINISH	MATERIAL	DESCRIPTION
1	GOLD	COPPER	HEAT SHRINK TUBE
1	GOLD	BER. COPPER	FERRULE
1	NATURAL	TEFLON	INSULATOR
1	GOLD	BRASS	BODY

UNLESS OTHERWISE SPECIFIED DIMENSIONS ARE IN MILLIMETERS. DIMENSIONS IN [] ARE IN INCHES AND FOR CUSTOMER REFERENCE ONLY.	UNLESS OTHERWISE SPECIFIED TOLERANCES FOR MILLIMETERS ARE:	UNLESS OTHERWISE SPECIFIED TOLERANCES FOR INCHES ARE:
	0.5 - 8mm ± 0.20mm	.020 - .315 = ± 0.007"
	8 - 30mm ± 0.40mm	.315 - 1.180 = ± 0.015"
	30 - 120mm ± 0.50mm	1.180 - 4.724 = ± 0.020"

APPROVALS	DATE
DRAWN G.R.S.	07/20/05
CHECKED	
ISSUED	
SHEET 1 OF 1	

PART DESCRIPTION	PART NO.
SMB CRIMP PLUG (FOR RG-178/U, 196/U CABLE)	1422229

CAD FILE	DWG. NO.	REV.	SIZE	SCALE
C:/142/142229.DWG	1422229.DWG	A	A	NA

Amphenol Connex