

NOTES:

- CONNECTOR SHALL MEET REQTS. OF MIL-C-3608.
- ALL DIMENSIONS ARE REFERENCE ONLY.
- OUTER CONTACTS: PHOSPHOR BRONZE.

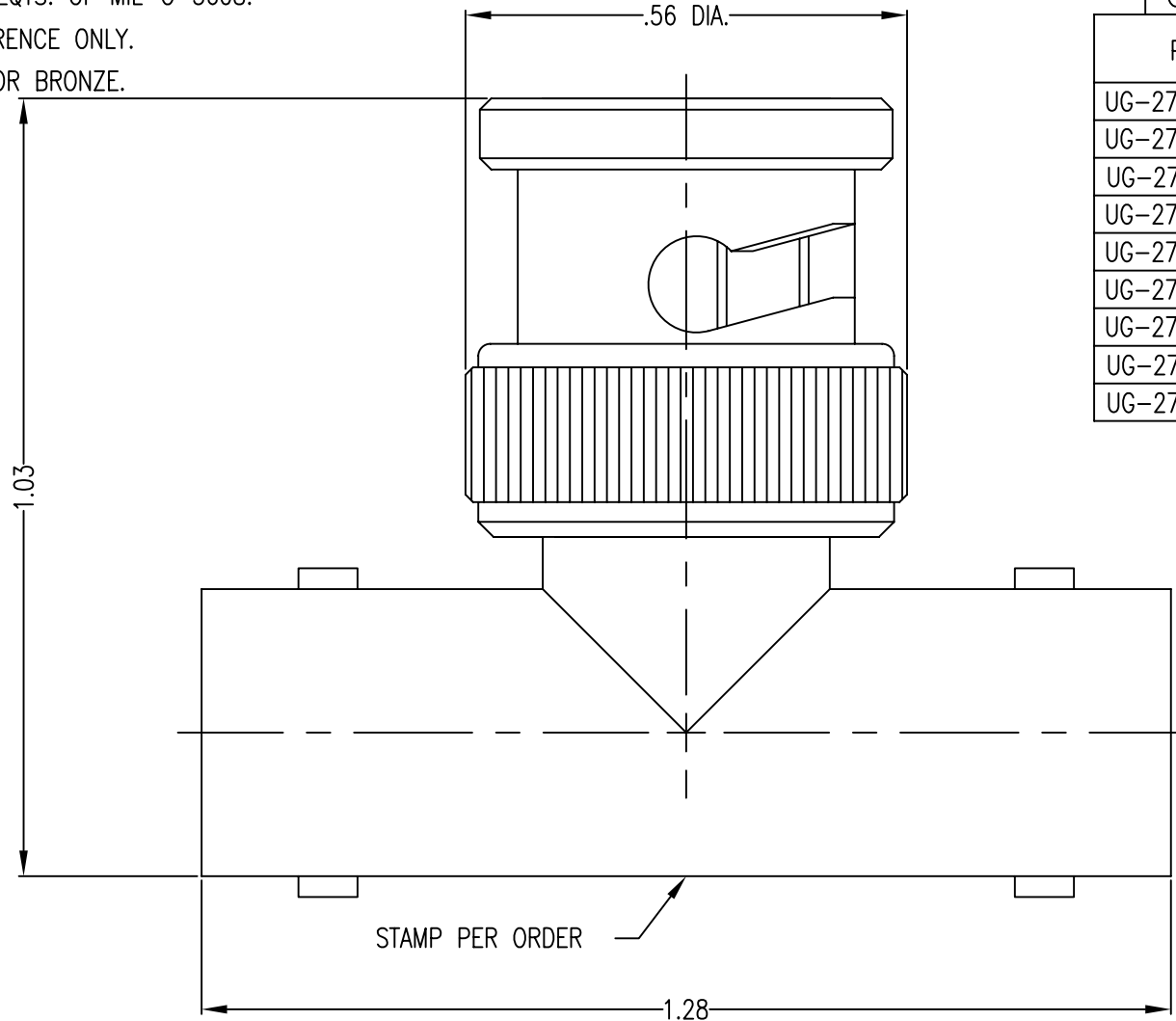

DWG NO. OL-274B-1 REV. A

PART NO.	BODY PLATING	CONTACT PLATING
UG-274A/U	NICKEL	SILVER
UG-274A/U Ni/GOLD	NICKEL	GOLD
UG-274A/U SI	SILVER	SILVER
UG-274B/U	NICKEL	SILVER
UG-274B/U Ni/GOLD	NICKEL	GOLD
UG-274B/U SI	SILVER	SILVER
UG-274B/U SI/GOLD	SILVER	GOLD
UG-274C/U	NICKEL	GOLD
UG-274C/U SI	SILVER	GOLD

STAMP PER ORDER

PROPRIETARY
THIS DRAWING CONTAINS CONFIDENTIAL INFORMATION
PROPRIETARY TO SAN*TRON INC. IT MUST NOT BE
REPRODUCED OR DISCLOSED TO OTHERS OR USED IN
ANY OTHER WAY, IN WHOLE OR PART EXCEPT AS
AUTHORIZED IN WRITING BY SAN*TRON INCORPORATED.

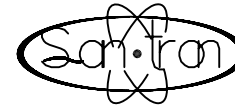

SAN • TRON, INC.

4 NEWBURYPORT TPK, IPSWICH, MA 01938

REMOVE ALL BURRS AND SHARP
EDGES .005 MAX.
UNLESS OTHERWISE STATED
ALL DIMENSIONS ARE IN INCHES
AND APPLY AFTER PLATING

TITLE BNC "T" ADAPTER (F)
TO (M) TO (F)

Rev.	Revisions	Date	Dwn.	Appd.
A	ORIGINAL	10/8/99		
RECOM.	STOCK SIZE	FT/M PCS	QTY REQD	

UNSPECIFIED TOL.	DWN	MM	10/8/99
DEC. ± .005	CHKD		
FRAC. ± 1/64	APPR		
ANG. ± 1/2°			

MATERIAL:	FINISH:
FSCM NO. 50896	DWG NO. OL-274B-1
SCALE 4:1	REV. A

CONCENTRICITY .004 TIR
ALL MACHINED SUFACES

63/