

CAD DRAWING - NO MANUAL REVISIONS

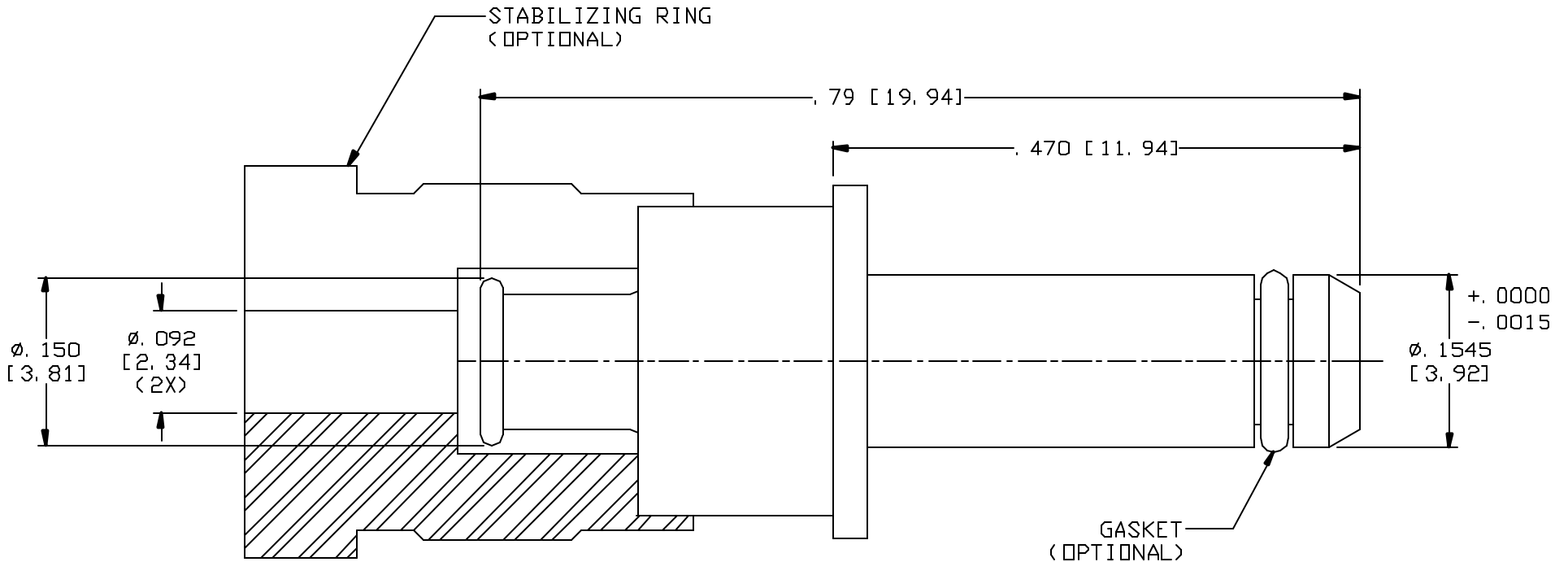

68-0020-0861	WITHOUT GASKET
68-0021-0861	WITH GASKET
68-0022-0861	WITH GASKET AND STABILIZING RING

NOTES:

1. PROCESS ALL ECNs PER DS-12.
2. DESIGN AND INTERFACE PER I. D. S. -68.
3. FOR USE WITH .086 OR EQUIVALENT CABLE.
4. USE IN ARING 600 CONNECTOR PER MIL-C-83527, SIZE #8.
5. USE INSERTION/WITHDRAWAL TOOL T-0617.
6. STABILIZING RING SUPPLIED LOOSE.
7. RAYTHEON DRAWING 7018414, REV. D.

G	PER ECN 10634	10/06/10	MS	PALCO CONNECTOR 22 GREAT HILL RD., NAUGATUCK, CT 06770 UNLESS OTHERWISE SPECIFIED, PALCO WORKMANSHIP STANDARDS APPLY TOLERANCES ON: DECIMALS: XX ± .01 .XXX ± .005 ANGLES ±1/2° 32' DIMENSIONS IN INCHES OR (METRIC) DO NOT SCALE PRINTS	DRAWN	CHECKED	ENGINEER	APPROVED	FSCM
F	PER ECN 10001	08/25/09	MS		EK	JEM	HN	JEM	58167
E	PER ECN 8206	10/03/05	JEM		DESCRIPTION PKZ PLUG, STRAIGHT DIRECT SOLDER				
D	PER ECN 8190	09/14/05	JEM			DATE	DRAWING NO.	PLATING OPT.	
C	PER ECN 7903	03/29/05	JEM		11/02/04	68-002X-0861	A, B, C, D		
REV.	DESCRIPTION	DATE	APPR.	EPR 550B 1					

THE INFORMATION IN THIS DOCUMENT IS CONFIDENTIAL AND PROPRIETARY AND MAY NOT BE USED FOR ANY PURPOSE WITHOUT THE WRITTEN CONSENT OF PALCO.