

CAD DRAWING - NO MANUAL REVISIONS

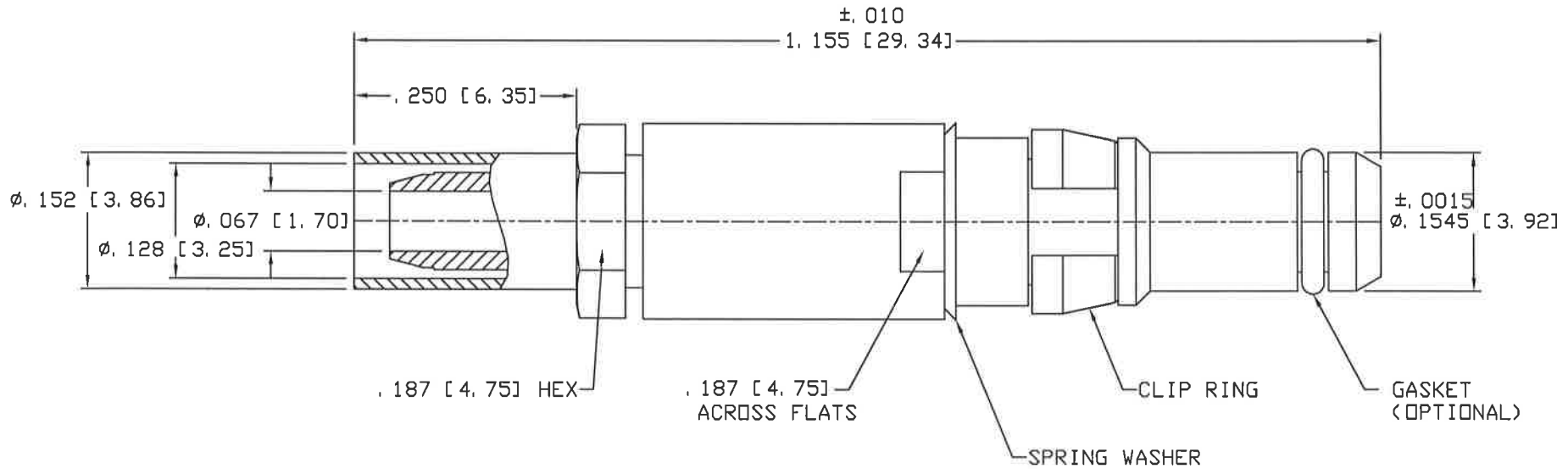

NOTES:

1. DESIGN AND INTERFACE PER I. D. S. -26.
2. BULLET, CLAMP NUT, FERRULE & SPACER SUPPLIED LOOSE.
3. ACCOMMODATES RG-316 OR EQUIVALENT CABLES.
4. CRIMP USING .128 HEX DIE (M22520/5-03).

PART NUMBER	GASKET OPTION	TYPE OF GASKET	MATERIAL
26-0080-0670	WITHOUT GASKET		
26-0081-0670	WITH GASKET	WEATHER PROOF	SILICON
26-0083-0670	WITH GASKET	EMI GASKET, *	BE CU, CANTED COIL
26-0085-0670	EMI RING	EMI GASKET	BE CU, SOLID RING

R	PER ECN 10690	11/08/10	JEM	<h2 style="margin: 0;">PALCO CONNECTOR</h2> <p style="margin: 0;">22 GREAT HILL RD., NAUGATUCK, CT 06770</p> <p style="margin: 0;">UNLESS OTHERWISE SPECIFIED, PALCO WORKMANSHIP STANDARDS APPLY</p> <p style="margin: 0;">TOLERANCES ON: DECIMALS: XX ±.01 .XXX ±.005 ANGLES ±1/2° 32</p> <p style="margin: 0;">DIMENSIONS IN INCHES OR (METRIC) DO NOT SCALE PRINTS</p>	DRAWN EK	CHECKED JEM	ENGINEER EK	APPROVED JEM	FSCM 58167
P	PER ECN 10292	04/20/10	JEM		DESCRIPTION PKZ PLUG CRIMP/CLAMP				
D	PER ECN 10128	12/15/09	JEM			DATE 03/07/91	DRAWING NO. 26-008X-0670	PLATING OPT. A, B, C, D	
N	PER ECN 7705	11/19/04	JEM						
M	PER ECN 4433	03/20/98	HN						
REV.	DESCRIPTION	DATE	APPR.	CATALOG ITEM					

THE INFORMATION IN THIS DOCUMENT IS CONFIDENTIAL AND PROPRIETARY AND MAY NOT BE USED FOR ANY PURPOSE WITHOUT THE WRITTEN CONSENT OF PALCO.