

Special Note - Product Has Been Supplanted by [HPR055](#) Series, which is recommended for ALL NEW APPLICATIONS - [Contact NexTek](#) for More Information and Assistance!

High Current DC Feedthrough Filter - 50 Amp



- ✓ Excellent EMI filtering
- ✓ Compact and lightweight
- ✓ "C" Type Filter
- ✓ Bolt-in style
- ✓ High Shock & Vibration
- ✓ CDR and JAN Reliability levels available

Voltage & Capacitance

50A		Capacitance μF																						
		.01	.015	.022	.033	.047	.068	.1	.15	.22	.33	.47	.68	1.0	1.5	2.2	3.3	4.7	6.8	10	15	22		
Rated Voltage	Vdc	50						+				+				+		+						
		100						+				+				+		+						
		200						+				+				+								
		500						+				+												

+ Standard Values

Insertion Loss

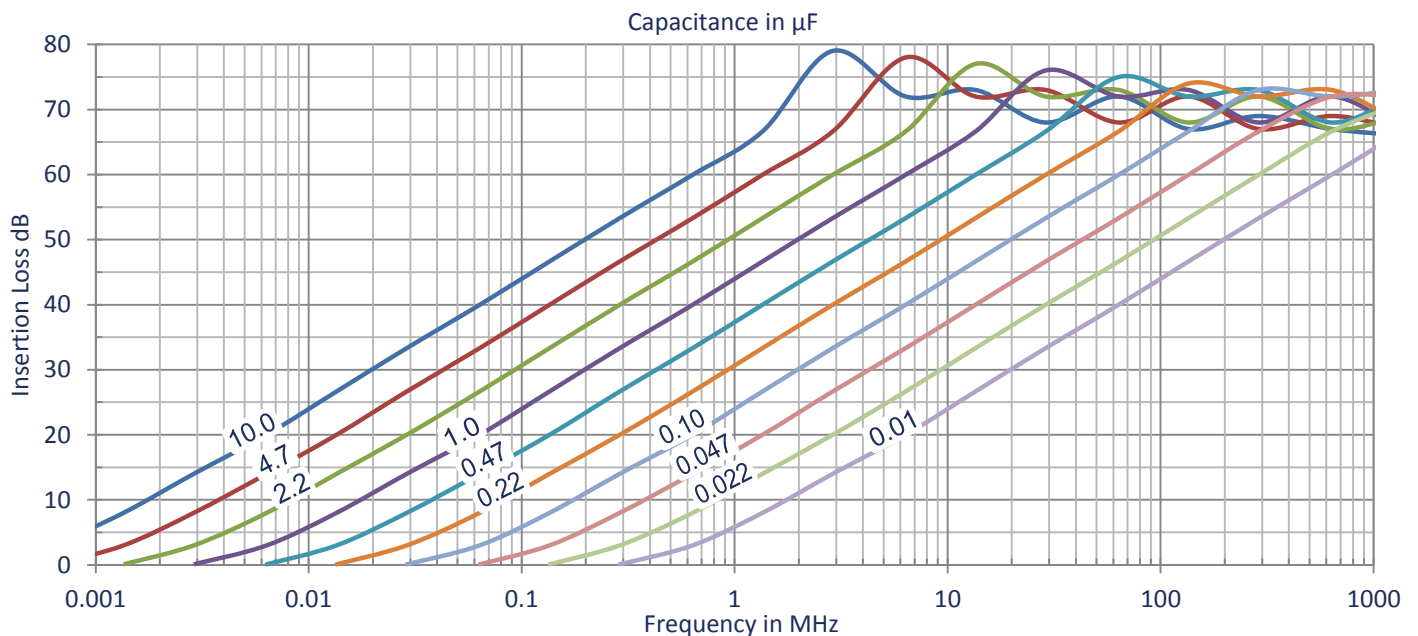

Specifications (Units to MIL-C-49467, MIL-C-55681, MIL-C-123 or customer SCD available in E-Series)

Parameter	Value	Description / Specification / Method
Current	50 Amperes	50, 55, 140, 175, 250, & 400 Amps available
Insertion Loss	See Performance Curve on page 1	Per Capacitor Value
RF Current	10A _{rms}	
Insulation Resistance	100ΩF (100MΩ Maximum) at 25°C	MIL-STD-202 Method 302
Dielectric Withstand Voltage	250% Rated Voltage (50mA 5s)	MIL-STD-202 Method 301
Dissipation Factor	3% Maximum	MIL-STD-202 Method 306
Voltage Drop (typical)	17mV	Wire to Wire
Operating Temp	-55°C to +125°C	5A@125°C to 50A@105°C
Temperature Rise	19.5°C Typical at 50A	
Heat Rise Constant	10.3 to 22	C ₁ in formula ΔT=C ₁ x W ^{0.85}
Storage Temperature	-55°C to +105°C	
Fungus	Non-Nutrient	MIL-HDBK-454A
Corrosion (metal finish)	5% NaCl / 35°C / 48 hrs	MIL-STD-202 Method 101D / Cond B
Humidity	98%RH 25°C-65°C	MIL-STD-202 Method 106E
Shock	30g – 11ms	MIL-STD-202 Method 213B / Cond A
Terminal Strength	Pull: 50lbs (23kg) Torque: 50"lbs (5.6Nm)	MIL-STD-202 Method 211A / Cond A & E
Reliability(MTBF)	500,000 hrs	MIL-HDBK-217F Cond - N2 A(IF) 70°C 50%V

Mechanical Specifications

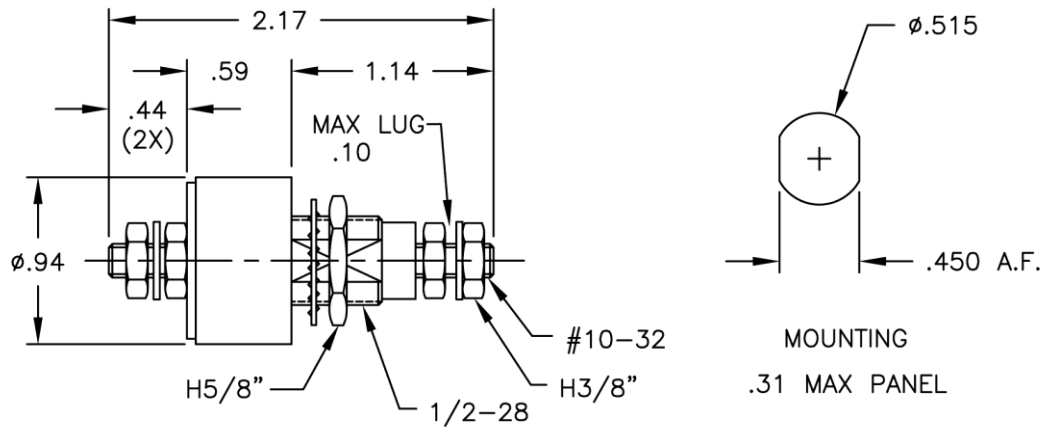

Component	Material	Finish
Metal Parts	Copper Alloy	Nickel
Insulator	FR4 or Nylon	-

Mounting

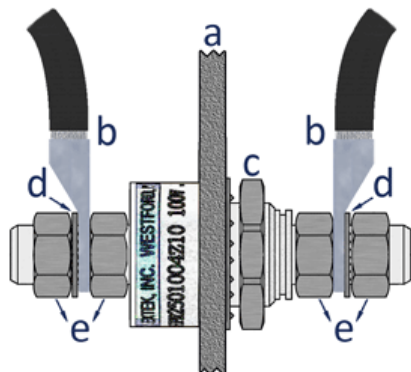

- a. Mounting Panel
- b. Lug / Wire
- c. Mounting Nut
- d. Washer
- e. Electrode Lug Nut

Mounting & Electrode Torque: 50"lbs (5.6Nm)

Part Number

Device	Current	Capacitance	Tolerance	Voltage	Series
HPR	050	XXXX	X	XX	X

- Device** HPR High Current Feedthrough Filter
- Current** Current rating in amperes
- Capacitance** in picofarads, first two digits are significant, last two digits are number of zeros
e.g. 2203 = 22,000pF / 4704 = .47μF
- Tolerance** Capacitor Code: Z= +80%/-20% (Standard), M= +/-20%, K= +/-10%, J=+/-5%
- Voltage** Rating Code: 10=100V, 20=200V, 50=500V
- Series** Optional series designator

Example:

HPR0501004Z10 = Feedthrough Filter / 50A / 0.10uF / +80%/-20% / 100Vdc

Safety Tips

- ✓ The filter should be mounted in a grounded shielding panel
- ✓ Tighten the electrode nuts to the torque specified with the two wrench method
- ✓ Cover exposed electrode nuts
- ✓ Observe temperature, current, & voltage limits