

5

4

3

2

1

REVISIONS				
REV	DESCRIPTION	ECO #	DATE	APPROVED
-	INITIAL RELEASE	14-388	11/17/14	T.KUHN

SPECIFICATIONS

MECHANICAL

BODY & NUT \_\_\_\_\_ STAINLESS STEEL  
 IAW ASTM-A484 & ASTM-A582,  
 ALLOY 303, COND A,  
 GOLD PLATED

GASKET \_\_\_\_\_ SILICON RUBBER AA-59588,  
 CLASS 2, GRADE 50

MARKING

PART LOOKS LIKE PRODUCT IMAGE ABOVE.  
 PART MARKING ORIENTATION AND FORMAT AS SHOWN.  
 MARKING TO BE AS LARGE AS POSSIBLE, CLEAR, AND READABLE.  
 YYWW = DATE CODE.

IAW WITH HONEYWELL 876808-00

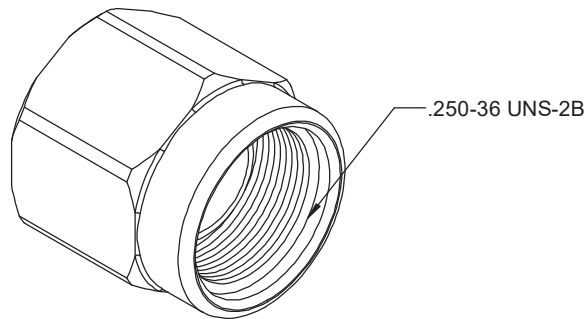
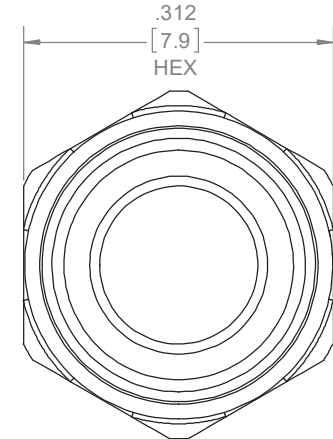
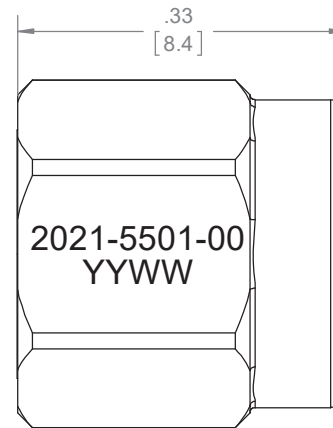

QTY.	PART NUMBER	DESCRIPTION	ITEM NO.
X	2021-5501-00	DUST CAP, SMA-m, CUSTOM	
1	TA-2021-5501-00U	ASSEMBLY, DUST CAP, SMA-m, CUSTOM, UNMARKED	1

DRAWING PRACTICES PER ANSI-Y-14.5  
 MIL-STD-100 & 1000

DIMENSIONS ARE IN INCHES AND  
 APPLY BEFORE / AFTER PROCESSING

SURFACE  
 ROUGHNESS  $\sqrt{63}$   
 μINCHES

FINISH:

SEE NOTES

MATERIAL:

SEE NOTES

NOTE:  
 THIS DRAWING INCORPORATES  
 THIRD ANGLE PROJECTION.

INTERPRET IAW ANSI Y14.5-1982

UNLESS OTHERWISE SPECIFIED  
 TOLERANCES IN:

DECIMALS	INCH	(MM)
.X"	.05"	[1.27]
.XX"	.03"	[.76]
.XXX"	.010"	[.25]

ANGLES ±0°30'

REMOVE ALL BURRS/SHARP W/  
 BREAK / R OF .003" TO .0005"  
 UNLESS OTHERWISE NOTED  
 DIAS CONCENTRIC <.003 T.I.R.

DO NOT SCALE PRINT

DRAWN DATE  
 MCCORMICK 11/17/14

CHECKED DATE  
 MCCORMICK 11/17/14

ENG. APPR. DATE  
 T.KUHN 11/17/14



Phone: 603-222-2256 Fax: 603-222-2259  
 150 Dow Street, Manchester, NH 03101

TITLE  
DUST CAP, SMA-m, CUSTOM

SIZE	CAGE CODE	DRAWING NUMBER	REV
B	3HT76	2021-5501-00	-

SCALE PLATED AREA SQ. IN SHEET 1 OF 1

5

4

3

2

1