

- 1.0 MATERIALS
- 1.1 ALL METAL PARTS: BRASS, ASTM-B-16
- 1.2 GASKET: SILICON RUBBER, ZZ-R-765, GR. 50, RED
- 2.0 FINISHES
- 2.1 METAL PARTS: NICKEL PLATED

DWG NO. OL-913MX-1		REV. B
PART NUMBER	CHAIN LENGTH	
MX-913/U	2.25"	
MX-913/U M3.2	3.2"	
MX-913/U M4.0	4.0"	

DO NOT SCALE DRAWING

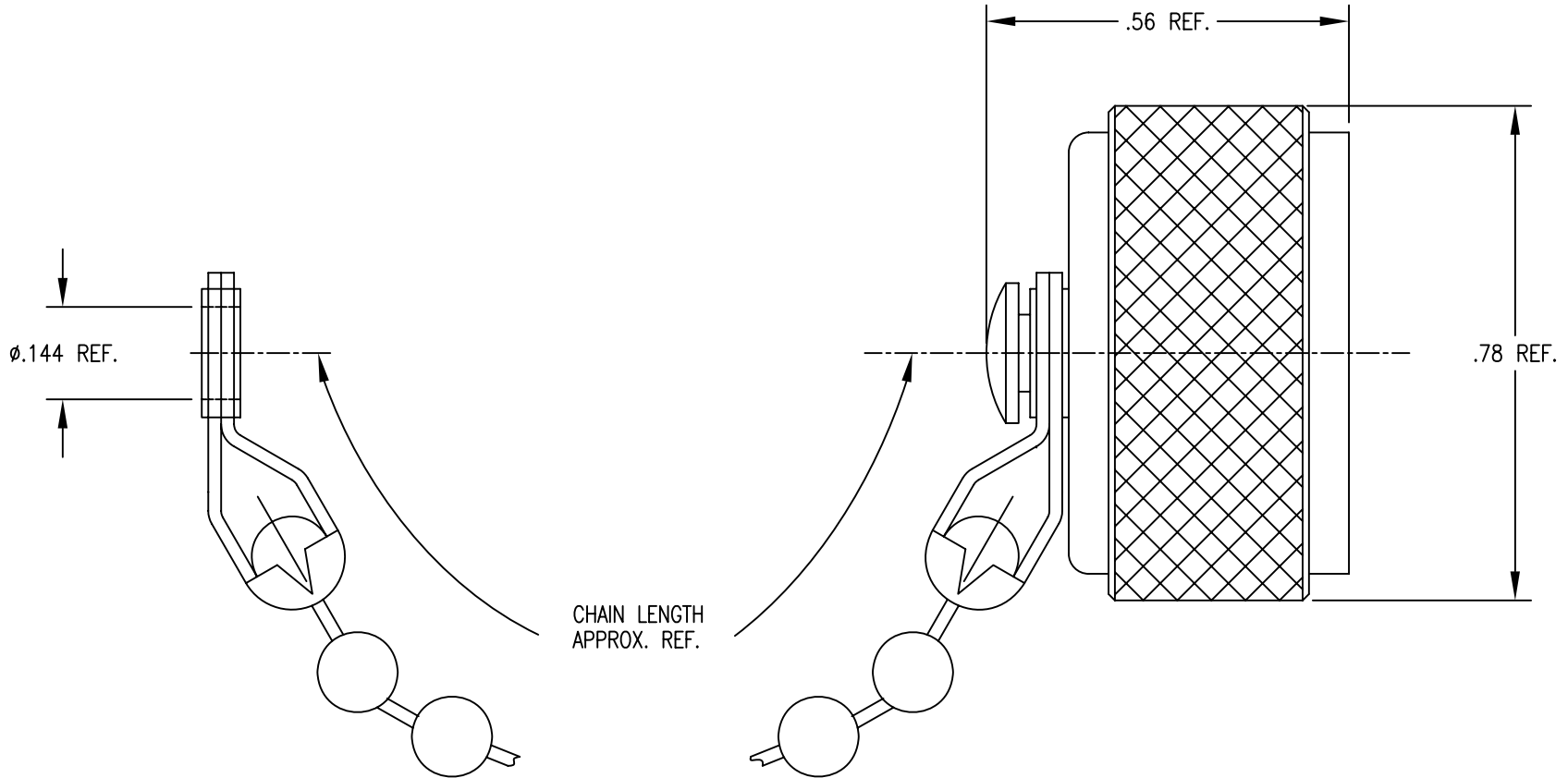

CHAIN LENGTH
APPROX. REF.

B	ISSUED NEW CHAIN LENGTHS	NEW	11/8/07	JTH	FSH		
A	ORIGINAL	NEW	12/7/01				
Rev.	Revisions	Disp.	Date	Dwn.	Appd.		
	Ref.: SK-	REMOVE ALL BURRS AND SHARP EDGES .005 MAX.	INTERPRET PER ASME Y14.5M-1994				

THIS DRAWING CONTAINS CONFIDENTIAL INFORMATION PROPRIETARY TO SAN-TRON, INC. IT MUST NOT BE REPRODUCED OR DISCLOSED TO OTHERS OR USED IN ANY OTHER WAY, IN WHOLE OR PART EXCEPT AS AUTHORIZED IN WRITING BY SAN-TRON, INC.

UNLESS OTHERWISE SPECIFIED:
ALL DIMENSIONS ARE IN INCHES.
ALL DIMENSIONS ARE AFTER PLATING.
.XXX = ±.005 ALL MACHINED SURFACES 32/ MAX.
.XX = ±.01 ANG. ±1/2' FRACTIONAL = ±1/64
Ⓞ.004 MAX. TIR ⊥ AXIS .001

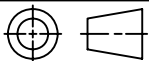

THIRD ANGLE PROJECTION

DWN	JMB	8/25/00
CHKD	SJS	12/6/07
APPR		



SAN-TRON, INC.

4 NEWBURYPORT TPK. IPSWICH MA USA 01938
TEL: 978 - 356 -1585 FAX: 978 - 356 -1573
WWW.santron.com E MAIL: santron@santron.com

TITLE
N MALE DUST CAP

MATERIAL: FINISH:
 NICKEL

CAGE CODE: 50896	DWG NO. OL-913MX-1	REV. B
SCALE X:X		