

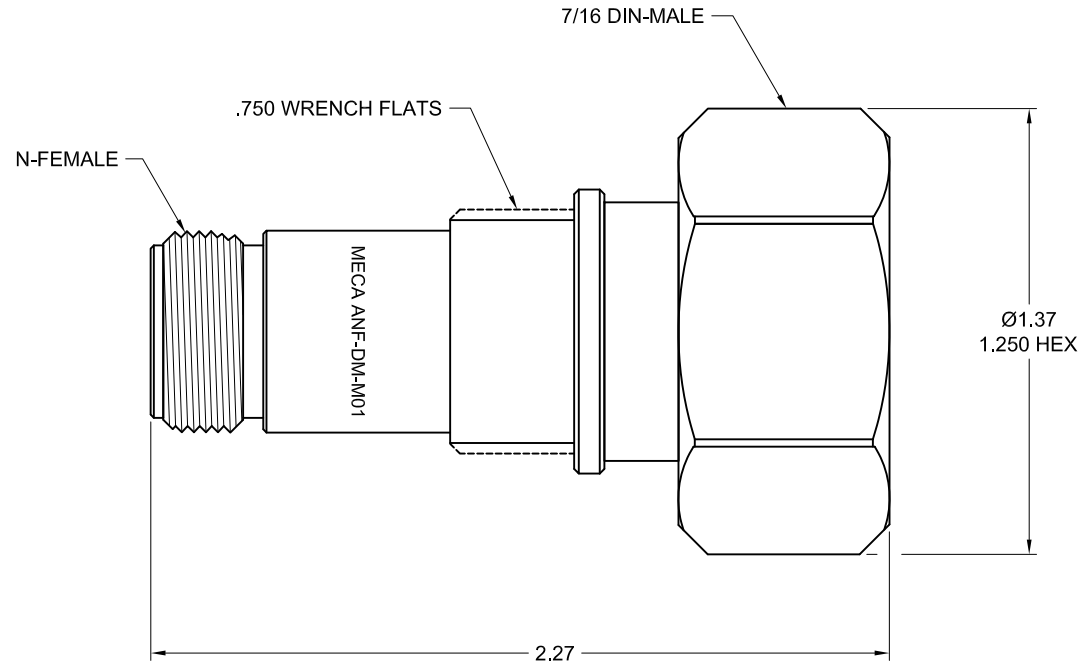

ELECTRICAL SPECIFICATIONS

FREQUENCY RANGE (GHz):	Hz - 8.0
IMPEDANCE (NOMINAL):	50 Ohms
VSWR (MAX):	
Hz - 1.0 GHz:	1.05:1
1.0 - 4.0 GHz:	1.15:1
4.0 - 8.0 GHz:	1.25:1
PIM:	< -165 dBc

MECHANICAL SPECIFICATIONS

CONNECTORS:	BRASS, ALBALOY PLATE
CONNECTOR PINS:	BERYLLIUM COPPER, SILVER PLATE
INSULATORS:	PTFE, VIRGIN ELECTRICAL GRADE
TEMPERATURE:	-55°C TO +85°C
WEIGHT (NOMINAL):	4.35 oz



					MATERIAL: SEE ABOVE	UNLESS OTHERWISE SPECIFIED, DIMENSIONS ARE IN INCHES		 ELECTRONICS, INC. DENVER, NEW JERSEY e-MECA.com			
					FINISH: SEE ABOVE	TOLERANCES 2 PLACES: ±.01 3 PLACES: ±.005 ANGLES: N/A					
C		SEE DCN #130423-1	04/23/13	NL	RR				TITLE ADAPTER, N-FEMALE TO DIN-MALE		
B		SEE DCN #120222-1	02/23/12	M.OC.	RR	DRAWN: NL	DATE: 03/16/11	TIR: N/A			
A		NEW	03/16/11	NL	RR	APPROVED: RR	DATE: 03/16/11	SCALE: NTS			
LTR	PG	DESCRIPTION	DATE	DR	APP			SIZE A	CAGE CODE NO. 22424	DRAWING NO. ANF-DM-M01	REV C