

NOTES:

- CONNECTORS SHALL MEET APPLICABLE REQTS. OF MIL-C-71A .
- ALL DIMENSIONS ARE REFERENCE ONLY .

DWG NO. OL-83B-1	REV. A
---------------------	-----------

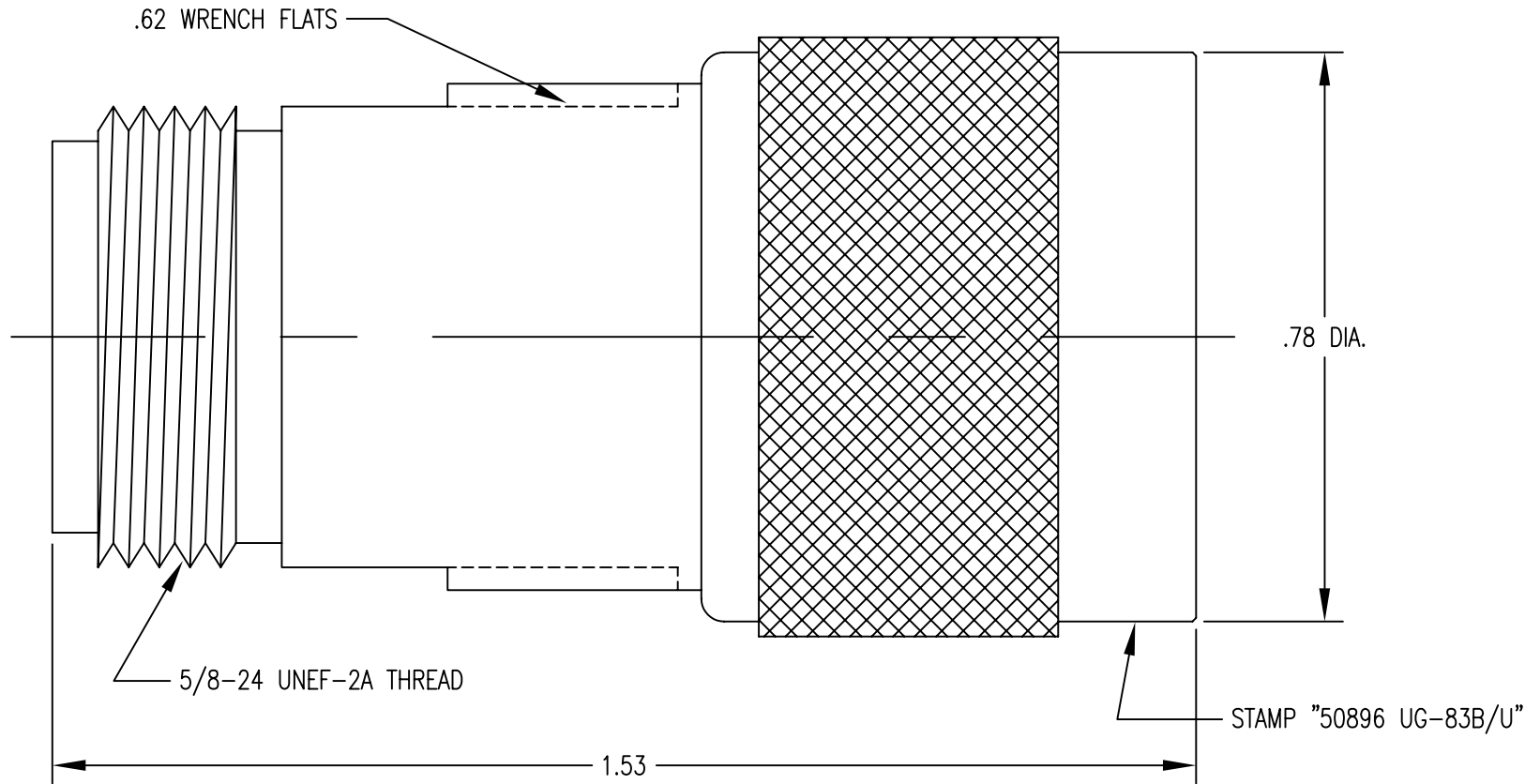

A	ORIGINAL	1/10/97		
Rev.	Revisions	Date	Dwn.	Appd.
	RECOM. STOCK SIZE	FT/M PCS	QTY REQD	

PROPRIETARY
THIS DRAWING CONTAINS CONFIDENTIAL INFORMATION PROPRIETARY TO SAN*TRON INC. IT MUST NOT BE REPRODUCED OR DISCLOSED TO OTHERS OR USED IN ANY OTHER WAY, IN WHOLE OR PART EXCEPT AS AUTHORIZED IN WRITING BY SAN*TRON INCORPORATED.

REMOVE ALL BURRS AND SHARP EDGES .005 MAX.
UNLESS OTHERWISE STATED ALL DIMENSIONS ARE IN INCHES AND APPLY AFTER PLATING

UNSPECIFIED TOL.	DWN	KC	1/10/97
DEC. ± .005	CHKD	SJS	1/14/97
FRAC. ± 1/64	APPR		
ANG. ± 1/2'			

CONCENTRICITY .004 TIR
ALL MACHINED SUFACES \checkmark 63



SAN • TRON, INC.
4 NEWBURYPORT TPK, IPSWICH, MA 01938

TITLE ADAPTER "UHF" (M) N(F)	
MATERIAL:	FINISH: NICKEL CONTACT: SILVER
FSCM NO. 50896	DWG NO. OL-83B-1
SCALE 4:1	REV. A