

NOTES:

25-984-0000-90

Materials: SST. corrosion-resistant, Non Magnetic 303, per ASTM A484 and A582. Beryllium Copper per ASTM-B-196, QQ-C-530 Oxide-Noryl (tm), MIL-P-46129

Finish: Center Conductors and solder components shall be plated per MIL-G-45204 Type II, Class 1 over Nickel plate per QQ-N-290. Body and Body components shall be passivated per ASTM A380.

Frequency: DC-40 GHz

VSWR: 1.25 TO 40 GHz

Insertion Loss: $.05\sqrt{\text{Frequency}}$

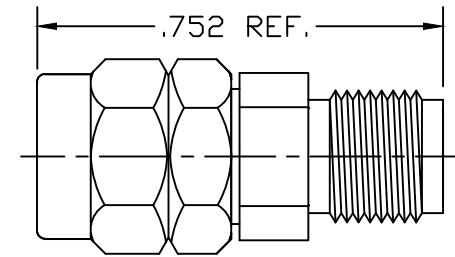

LTR	DESCRIPTION	DATE	APPR.	DRAWN LMW	CHECKED	USED ON	 SRI CONNECTOR GAGE CO. 751 NORTH DRIVE MELBOURNE FL. 32934	
-	REL	05/03		APPR.	SCALE	25-984-0000-90	TITLE	
				UNLESS OTHERWISE SPECIFIED: 1. REMOVE ALL BURRS 2. BREAK ALL CORNERS & EDGES .005 R. MAX 3. CHAMFER 1st & LAST THREADS 45° 4. SURFACE FINISHED 32✓ UNLESS OTHERWISE SPECIFIED. 5. DIAMETERS ON COMMON CENTERS TO BE CONCENTRIC WITHIN .002 T.I.R. 6. ALL DIMENSIONS ARE AFTER PLATING.		MATERIAL	2.9mm JACK TO 1.85mm PLUG	
				DIMENSIONS ARE IN INCHES TOLERANCES		FINISH		
				DECIMALS FRACTIONAL ANGULAR .X ±.030 .XX ±.010 ± 1/64 .X° ±1°0' .XXX +.005 .X°X' ±15'	SIZE	FSCM NO.	SHEET	DWG. NO.
					A	OHMO1	1	25-984-0000-90