

27-920-0000-00

NOTES:

Materials: SST. corrosion-resistant, Non Magnetic 303, per ASTM A484 and A582. Beryllium Copper per ASTM-B-196, QQ-C-530
Oxide-Noryl (tm), MIL-P-46129
PTFE Fluorocarbon per ASTM-D-1710 Type 1

Finish: Center Conductors and solder components shall be plated per MIL-G-45204 Type II, Class 1 over Nickel plate per QQ-N-290.
Body and Body components shall be passivated per ASTM A380.

Frequency: DC-27 GHz
VSWR: 1.2 TO 27 GHz
Insertion Loss: $.05\sqrt{\text{Frequency}}$

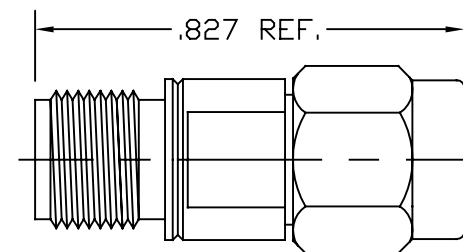

LTR	DESCRIPTION	DATE	APPR.	DRAWN LMW	CHECKED	USED ON	 SRI CONNECTOR GAGE CO. 751 NORTH DRIVE MELBOURNE FL. 32934		
-	REL	03/00		APPR.	SCALE	27-920-0000-00			
				UNLESS OTHERWISE SPECIFIED: 1. REMOVE ALL BURRS 2. BREAK ALL CORNERS & EDGES .005 R. MAX 3. CHAMFER 1st & LAST THREADS 45° 4. SURFACE FINISHED 32/ UNLESS OTHERWISE SPECIFIED. 5. DIAMETERS ON COMMON CENTERS TO BE CONCENTRIC WITHIN .002 T.I.R. 6. ALL DIMENSIONS ARE AFTER PLATING.		MATERIAL	TITLE		
				DIMENSIONS ARE IN INCHES TOLERANCES		FINISH			
				DECIMALS .X ±.030 .XX ±.010 .XXX ±.005	FRACTIONAL ± 1/64	ANGULAR .X° ±1°0' .X°X' ±15'	2.4mm JACK TO SMA PLUG		
						SIZE A		FSCM NO. OHMO1	SHEET 1