

26-923-0000-90

NOTES:

Materials: SST. corrosion-resistant, Non Magnetic 303, per ASTM A484 and A582. Beryllium Copper per ASTM-B-196, QQ-C-530 Oxide-Noryl (tm), MIL-P-46129

Center Conductors and solder components shall be plated per MIL-G-45204 Type II, Class 1 over Nickel plate per QQ-N-290.

Body and Body components shall be passivated per ASTM A380.

Frequency: DC-34.5 GHz
1.25 TO 34.5 GHz

Insertion Loss: $.05\sqrt{\text{Frequency}}$

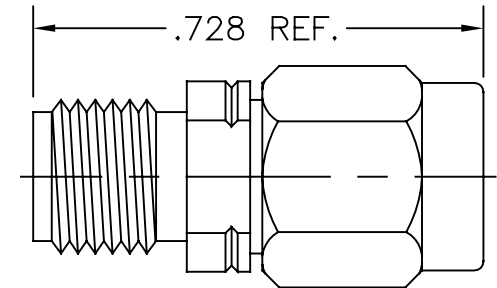

LTR	DESCRIPTION	DATE	APPR.	DRAWN LRH	CHECKED	USED ON	 SRI CONNECTOR GAGE CO. 751 NORTH DRIVE MELBOURNE FL. 32934		
-	REL	6/95		APPR.	SCALE NTS	26-923-0000-90			
				UNLESS OTHERWISE SPECIFIED: 1. REMOVE ALL BURRS 2. BREAK ALL CORNERS & EDGES .005 R. MAX 3. CHAMFER 1st & LAST THREADS 45° 4. SURFACE FINISHED 32/ UNLESS OTHERWISE SPECIFIED. 5. DIAMETERS ON COMMON CENTERS TO BE CONCENTRIC WITHIN .002 T.I.R. 6. ALL DIMENSIONS ARE AFTER PLATING.			TITLE		
				DIMENSIONS ARE IN INCHES TOLERANCES			2.4mm PLUG TO 3.5mm JACK		
				DECIMALS	FRACTIONAL	ANGULAR		MATERIAL	
				.X ±.030 .XX ±.010 .XXX +.005	± 1/64	.X° ±1'0" .X°X' ±15'		FINISH	
						SIZE A	FSCM NO. OHMO1	SHEET 1	DWG. NO. 26-923-0000-90