

NOTES:

52-924-0000-70

Materials: SST. corrosion-resistant, Non Magnetic 303, per ASTM A484 and A582. Beryllium Copper per ASTM-B-196, QQ-C-530 Oxide-Noryl (tm), MIL-P-46129

Finish: Center Conductors and solder components shall be plated per MIL-G-45204 Type II, Class 1 over Nickel plate per QQ-N-290. Body and Body components shall be passivated per ASTM A380.

Frequency: DC-18 GHz
1.15 TO 18 GHz

Insertion Loss: $.05\sqrt{\text{Frequency}}$

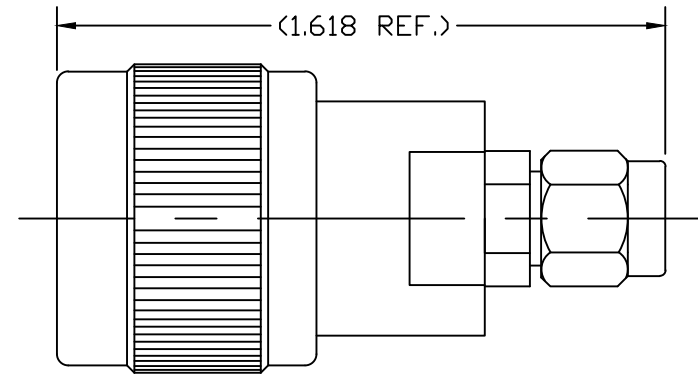

LTR	DESCRIPTION	DATE	APPR.	DRAWN <i>LMW</i>	CHECKED	USED ON	 SRI CONNECTOR GAGE CO. 751 NORTH DRIVE MELBOURNE FL. 32934													
-	REL	09/02		APPR.	SCALE	52-924-0000-70	TITLE													
				UNLESS OTHERWISE SPECIFIED: 1. REMOVE ALL BURRS 2. BREAK ALL CORNERS & EDGES .005 R. MAX 3. CHAMFER 1st & LAST THREADS 45° 4. SURFACE FINISHED 32✓ UNLESS OTHERWISE SPECIFIED. 5. DIAMETERS ON COMMON CENTERS TO BE CONCENTRIC WITHIN .002 T.I.R. 6. ALL DIMENSIONS ARE AFTER PLATING.		MATERIAL	N TYPE PLUG TO 2.4mm PLUG													
				DIMENSIONS ARE IN INCHES TOLERANCES		FINISH														
				<table border="1"> <tr> <th>DECIMALS</th> <th>FRACTIONAL</th> <th>ANGULAR</th> </tr> <tr> <td>.X ±.030</td> <td></td> <td>.X° ±1°0'</td> </tr> <tr> <td>.XX ±.010</td> <td>± 1/64</td> <td>.X°X' ±15'</td> </tr> <tr> <td>.XXX ±.005</td> <td></td> <td></td> </tr> </table>	DECIMALS	FRACTIONAL	ANGULAR	.X ±.030		.X° ±1°0'	.XX ±.010	± 1/64	.X°X' ±15'	.XXX ±.005			SIZE	FSCM NO.	SHEET	DWG. NO.
DECIMALS	FRACTIONAL	ANGULAR																		
.X ±.030		.X° ±1°0'																		
.XX ±.010	± 1/64	.X°X' ±15'																		
.XXX ±.005																				
				A	OHMO1	1	52-924-0000-70													