

NOTES:

26-920-0000-00

Materials: SST. corrosion-resistant, Non Magnetic 303, per ASTM A484 and A582. Beryllium Copper per ASTM-B-196, QQ-C-530 Oxide-Noryl (tm), MIL-P-46129 PTFE Fluorocarbon per ASTM-D-1710 Type 1

Finish: Center Conductors and solder components shall be plated per MIL-G-45204 Type II, Class 1 over Nickel plate per QQ-N-290. Body and Body components shall be passivated per ASTM A380.

Frequency: DC-27 GHz
 VSWR: 1.2 TO 27 GHz
 Insertion Loss: $.05\sqrt{\text{Frequency}}$

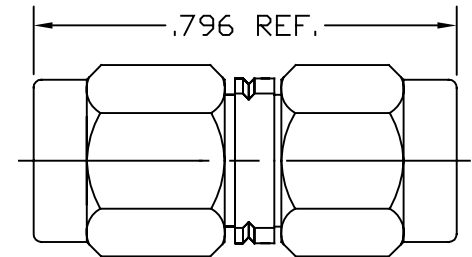

LTR	DESCRIPTION	DATE	APPR.	DRAWN LMW	CHECKED	USED ON	 SRI CONNECTOR GAGE CO. 751 NORTH DRIVE MELBOURNE FL. 32934	
-	REL	09/03		APPR.	SCALE	26-920-0000-00		
				UNLESS OTHERWISE SPECIFIED: 1. REMOVE ALL BURRS 2. BREAK ALL CORNERS & EDGES .005 R. MAX 3. CHAMFER 1st & LAST THREADS 45° 4. SURFACE FINISHED 32/ UNLESS OTHERWISE SPECIFIED. 5. DIAMETERS ON COMMON CENTERS TO BE CONCENTRIC WITHIN .002 T.I.R. 6. ALL DIMENSIONS ARE AFTER PLATING.		MATERIAL	TITLE	
				DIMENSIONS ARE IN INCHES TOLERANCES		FINISH	2.4mm PLUG TO SMA PLUG	
				DECIMALS .X ±.030 .XX ±.010 .XXX ±.005	FRACTIONAL ± 1/64	ANGULAR .X° ±1°0' .X°X' ±15'		SHEET 1
						SIZE A	FSCM NO. OHMO1	DWG. NO. 26-920-0000-00