

**NOTES:**

23-923-3500-30

**Materials:** SST. corrosion-resistant, Non Magnetic 303, per ASTM A484 and A582. Beryllium Copper per ASTM-B-196, QQ-C-530 Rexolite 1422

**Finish:** Center Conductors and solder components shall be plated per MIL-G-45204 Type II, Class 1 over Nickel plate per QQ-N-290. Body and Body components shall be passivated per ASTM A380.

**Frequency:** DC-34.5 GHz

**VSWR:** 1.25 TO 34.5 GHz

**Insertion Loss:**  $.05\sqrt{\text{Frequency}}$

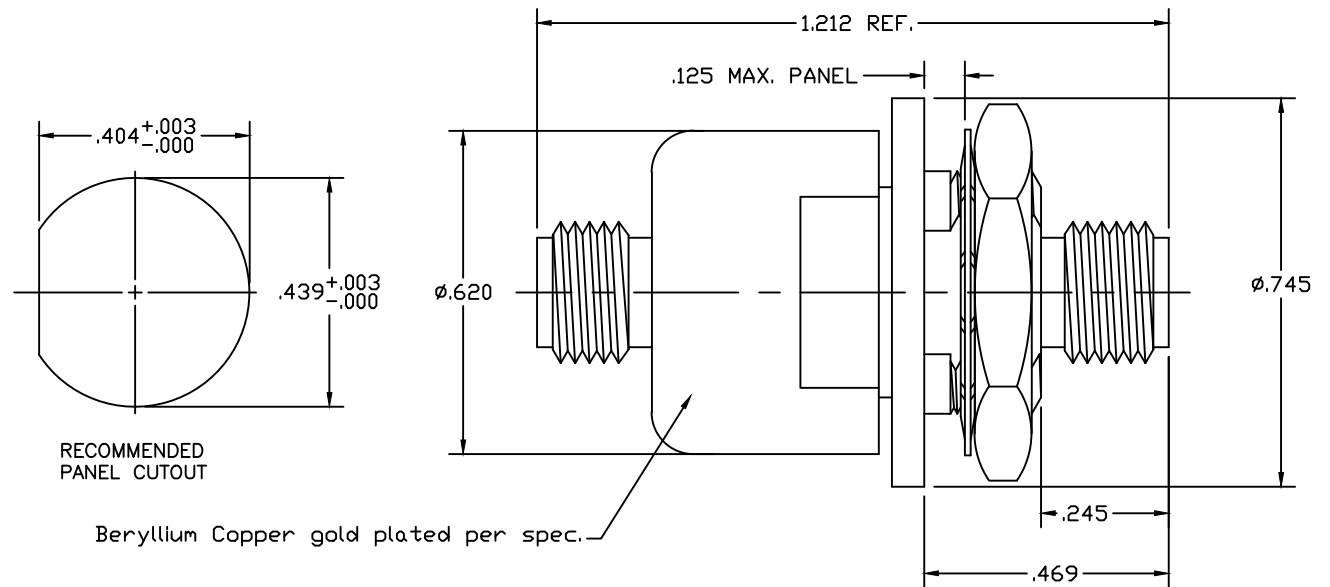

LTR	DESCRIPTION	DATE	APPR.	DRAWN <b>LMW</b>	CHECKED	USED ON	 SRI CONNECTOR GAGE CO. 751 NORTH DRIVE MELBOURNE FL. 32934
-	REL	05/03		APPR.	SCALE	23-923-3500-30	
				UNLESS OTHERWISE SPECIFIED: 1. REMOVE ALL BURRS 2. BREAK ALL CORNERS & EDGES .005 R. MAX 3. CHAMFER 1st & LAST THREADS 45° 4. SURFACE FINISHED 32/ UNLESS OTHERWISE SPECIFIED. 5. DIAMETERS ON COMMON CENTERS TO BE CONCENTRIC WITHIN .002 T.I.R. 6. ALL DIMENSIONS ARE AFTER PLATING.		MATERIAL	TITLE
				DIMENSIONS ARE IN INCHES TOLERANCES		FINISH	3.5mm JACK TO 3.5mm JACK BLKHD
				DECIMALS .X ±.030 .XX ±.010 .XXX +.005	FRACTIONAL ± 1/64	ANGULAR .X° ±1°0' .X'X' ±15'	
						SIZE A	FSCM NO. OHMO1
						SHEET 1	DWG. NO. 23-923-3500-30