

NOTES:

23-920-0000-00

Materials: SST. corrosion-resistant, Non Magnetic 303, per ASTM A484 and A582. Beryllium Copper per ASTM-B-196, QQ-C-530
Oxide-Noryl (tm), MIL-P-46129
PTFE Fluorocarbon per ASTM-D-1710 Type 1

Finish: Center Conductors and solder components shall be plated per MIL-G-45204 Type II, Class 1 over Nickel plate per QQ-N-290.
Body and Body components shall be passivated per ASTM A380.

Frequency: DC-27 GHz
VSWR: 1.2 TO 27 GHz
Insertion Loss: $.05\sqrt{\text{Frequency}}$

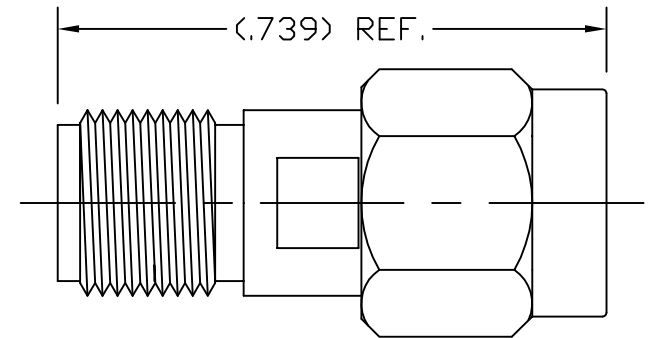

LTR	DESCRIPTION	DATE	APPR.	DRAWN LMW	CHECKED	USED ON	 SRI CONNECTOR GAGE CO. 751 NORTH DRIVE MELBOURNE FL. 32934													
-	REL	11/01		APPR.	SCALE	23-920-0000-00	TITLE													
				UNLESS OTHERWISE SPECIFIED: 1. REMOVE ALL BURRS 2. BREAK ALL CORNERS & EDGES .005 R. MAX 3. CHAMFER 1st & LAST THREADS 45° 4. SURFACE FINISHED 32/ UNLESS OTHERWISE SPECIFIED. 5. DIAMETERS ON COMMON CENTERS TO BE CONCENTRIC WITHIN .002 T.I.R. 6. ALL DIMENSIONS ARE AFTER PLATING.			3.5mm JACK TO SMA PLUG													
				DIMENSIONS ARE IN INCHES TOLERANCES			MATERIAL	SHEET												
				<table border="1"> <tr> <th>DECIMALS</th> <th>FRACTIONAL</th> <th>ANGULAR</th> </tr> <tr> <td>.X ±.030</td> <td></td> <td>.X° ±1°0'</td> </tr> <tr> <td>.XX ±.010</td> <td>± 1/64</td> <td>.X°X' ±15'</td> </tr> <tr> <td>.XXX ±.005</td> <td></td> <td></td> </tr> </table>			DECIMALS		FRACTIONAL	ANGULAR	.X ±.030		.X° ±1°0'	.XX ±.010	± 1/64	.X°X' ±15'	.XXX ±.005			FINISH
DECIMALS	FRACTIONAL	ANGULAR																		
.X ±.030		.X° ±1°0'																		
.XX ±.010	± 1/64	.X°X' ±15'																		
.XXX ±.005																				
						SIZE	FSCM NO.	1												
						A	OHMO1	23-920-0000-00												