

THIS DRAWING CONTAINS INFORMATION PROPRIETARY TO RF INDUSTRIES.  
 ANY UNAUTHORIZED USE OF THIS DRAWING IS EXPRESSLY PROHIBITED  
 WITHOUT WRITTEN PERMISSION FROM RF INDUSTRIES.  
 ANY VIOLATION IS PUNISHABLE UNDER U.S. COPYRIGHT LAWS.

ALL DIMENSIONS ARE REFERENCE ONLY

**SPECIFICATIONS:**

**IMPEDANCE RANGE:** 50 Ohms  
**FREQUENCY RANGE:** DC to 34 GHz  
**VSWR:** 1.04 + .006 f (f=GHz) Max. DC-34 GHz  
**CONTACT RESISTANCE:**  
 Outer Contact= 2.0 milliohms  
 Center Contact= 3.0 milliohms  
**CONNECTOR DURABILITY:** 500 Cycles minimum  
**TEMPERATURE RANGE:** -55° C TO 105° C

**MATERIALS:**

**Body and Body Components:**  
 Non-Magnetic stainless steel, per ASTM  
 A582, class 303 condition A.  
**Contacts:** Beryllium copper,  
 per QQ-C-530, heat treated per  
 MIL-H-7199  
**Insulators:** PTFE  
 MIL-P-19468, ASTM-D1710

**Center Contacts:**

.000050 min. gold per MIL-G-45204B  
 Type II, Grade C, Class 1  
 over .000050 min. Nickel per  
 QQ-N-290A

**Other Metal Parts:**  
 Passivated, (as specified)  
 to meet the finish and  
 corrosion requirements of MIL-C-39012.

#	DESCRIPTION	QTY	MATERIAL	FINISH	APPROVALS	DATE
1	BODY	1	SST. 303	PASSIVATE	000000	
2	BODY	1	SST. 303	PASSIVATE		
3	CONTACT	1	Be.Cu.	GOLD, 50µ"		
4	CONTACT	1	Be.Cu.	GOLD, 50µ"		
5	COUPLING NUT	1	SST. 303	PASSIVATE		
6	RETAINING RING	1	Be.Cu.	---		
7	GASKET	1	SILICONE	---		
8	DIELECTRIC	1	REXOLITE	---		
9						
10						
11						
12						
13						
14						

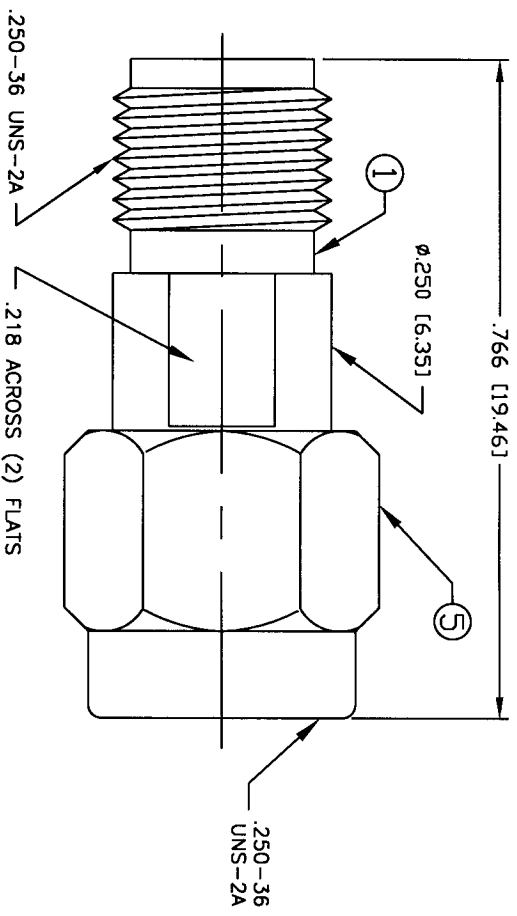

**UNLESS OTHERWISE SPECIFIED:**

- REMOVE ALL BURRS
- BREAK ALL CORNERS & EDGES .005 R. MAX.
- CHAMFER 1ST & LAST THREADS 45°
- SURFACE ROUGHNESS 63 FINISH MIL-STD-10
- DIAMETERS ON COMMON CENTERS TO BE CONCENTRIC WITHIN .002 T.I.R.
- ALL DIMENSIONS ARE AFTER PLATING.

**DIMENSIONS ARE IN INCHES AND [MILLIMETERS]**

UNLESS OTHERWISE NOTED TOLERANCES ARE:

DECIMALS .xxx±.003 [.08]

DIAMETER .xxx±.001 [.03]

xxx±.005 [.13]

PART NO.		DESCRIPTION		DWN	DATE	APPROVED
RF35M-35F-00000		ENGINEERING RELEASE		CZS	5/26/00	JDMc
REV						

**RF connectors**  
 DIVISION OF RF INDUSTRIES, LTD.

**3.5mm PLUG TO JACK**  
 ADAPTER

7610 MIRAMAR RD  
 SAN DIEGO, CA 92126  
 (858) 549-6340  
 (858) 549-6345 FAX

SIZE: A  
 CABLE GROUP: N/A  
 DWG. NO.: RF35M-35F-00000  
 SCALE: NTS  
 CAD FILE: OUTLINE  
 SHEET 1 OF 1