

**NOTES:**

20-920-2100-00

**DC-27 GHz -SMA HIGH FREQUENCY/HIGH PERFORMANCE CONNECTOR**

**Materials:** SST. corrosion-resistant, Non Magnetic 303, per ASTM A484 and A582. Beryllium Copper per ASTM-B-196, QQ-C-530  
PTFE Fluorocarbon per ASTM-D-1710

**Finish:** Center Conductors and solder components shall be plated per MIL-G-45204 Type II, Class 1 over Nickel plate per QQ-N-290.  
Body and Body components shall be passivated per ASTM A380.

**VSWR/Frequency:** 1.35:1 MAX. TO 27GHz

**Insertion Loss:**  $.05\sqrt{\text{Frequency}}$

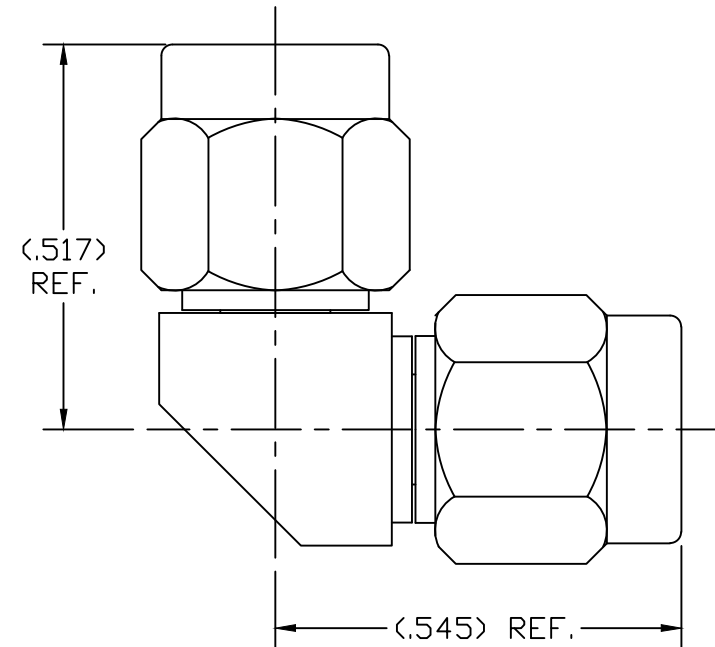

LTR	DESCRIPTION	DATE	APPR.	DRAWN <b>LMW</b>	CHECKED	USED ON	 SRI CONNECTOR GAGE CO. 751 NORTH DRIVE MELBOURNE FL. 32934			
-	REL	12/02		APPR.	SCALE	20-920-2100-00				
				UNLESS OTHERWISE SPECIFIED: 1. REMOVE ALL BURRS 2. BREAK ALL CORNERS & EDGES .005 R. MAX 3. CHAMFER 1st & LAST THREADS 45° 4. SURFACE FINISHED 32√ UNLESS OTHERWISE SPECIFIED. 5. DIAMETERS ON COMMON CENTERS TO BE CONCENTRIC WITHIN .002 T.I.R. 6. ALL DIMENSIONS ARE AFTER PLATING.		MATERIAL	TITLE			
						FINISH		SMA PLUG TO SMA PLUG R/A		
				DIMENSIONS ARE IN INCHES TOLERANCES		SIZE	FSCM NO.	SHEET	DWG. NO.	
				DECIMALS .X ±.030 .XX ±.010 .XXX +.005	FRACTIONAL ± 1/64	ANGULAR .X° ±1°0' .X'X' ±15'	A	OHMO1	1	20-920-2100-00