

REV.	DESCRIPTION	DATE	BY
E	SEE ECO GM-11508	4/10/00	MJC

MATERIAL AND FINISH

COUPLING NUT: CRES 303 PER ASTM A 484 AND ASTM A 582 OR ASTM A 555 AND ASTM A 581. PASSIVATE PER MIL-F-14072 E300.

CONTACT, GPO HOUSING, TYPE K PLUG HOUSING AND ANTI-ROCK RING: BERYLLIUM COPPER PER ASTM B 196 AND/OR ASTM B 197. GOLD PLATE PER MIL-G-45204; TYPE I, GRADE C, CLASS 1. OVER NICKEL PER QQ-N-290A; CLASS 1; 50 MICRONS MIN.

DIELECTRICS: VIRGIN PTFE FLUOROCARBON PER ASTM D 1710 AND ASTM D 1457.

RETAINING RING: BERYLLIUM COPPER PER ASTM B 196 AND/OR ASTM B 197.

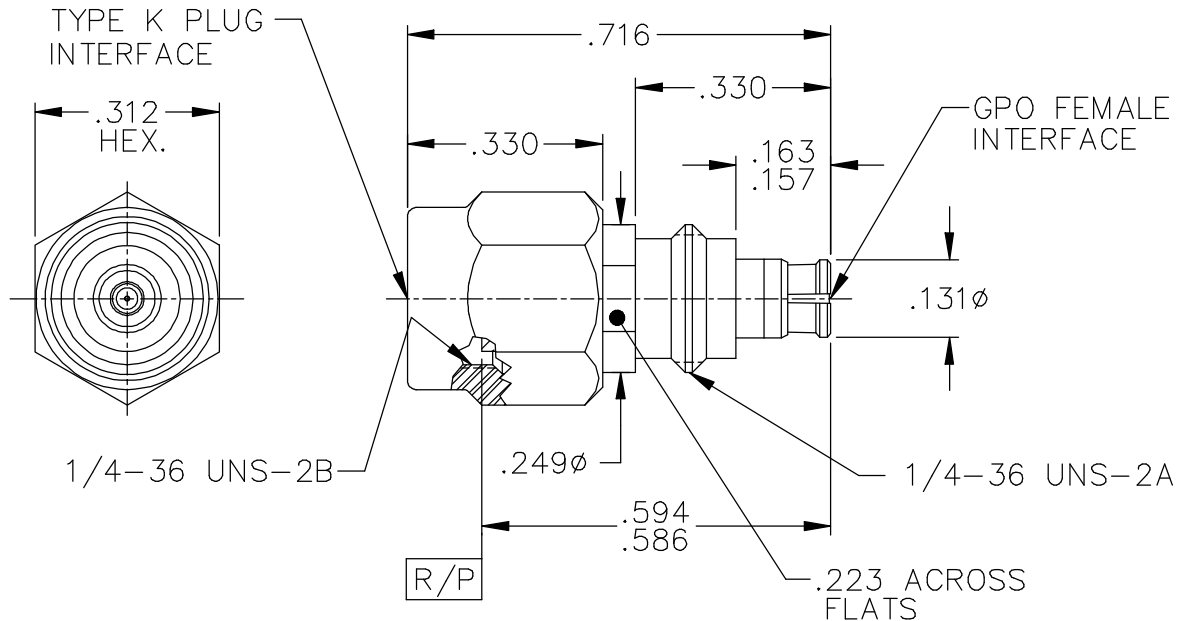

This drawing and any data contained therein is the property of Gilbert Engineering Co. Inc., and constitutes and contains proprietary and confidential information. Neither receipt nor possession of this drawing confers or transfers any right to duplicate, use or disclose any information contained herein except as expressly authorized by Gilbert Engineering Co. Inc.

ASSEMBLY PROCEDURES: NONE
 SOURCE FILE: MECR #613 SHT. 1 OF 1

ALL DIMENSIONS IN INCHES		CATALOG NUMBER 00117-205-1	CODE IDENT NO. 82316
DRAWN:	GILBERT ENGINEERING CO., INC.		
HCP	TITLE OUTLINE DRAWING FOR GPO FEMALE TO TYPE K PLUG ADAPTOR		
DATE	11-5-95		
DWG. NO.	0L-00117-205-1	REV E	