

CATALOG NUMBER

A1A1-0001-24

MATERIAL AND FINISH

CENTER CONTACT
AND HOUSING:BeCu; GOLD PLATE 50-100 MICRONS
OVER NICKEL PLATE 50 MICRONS MIN.

DIELECTRICS:

VIRGIN PTFE

GASKET:

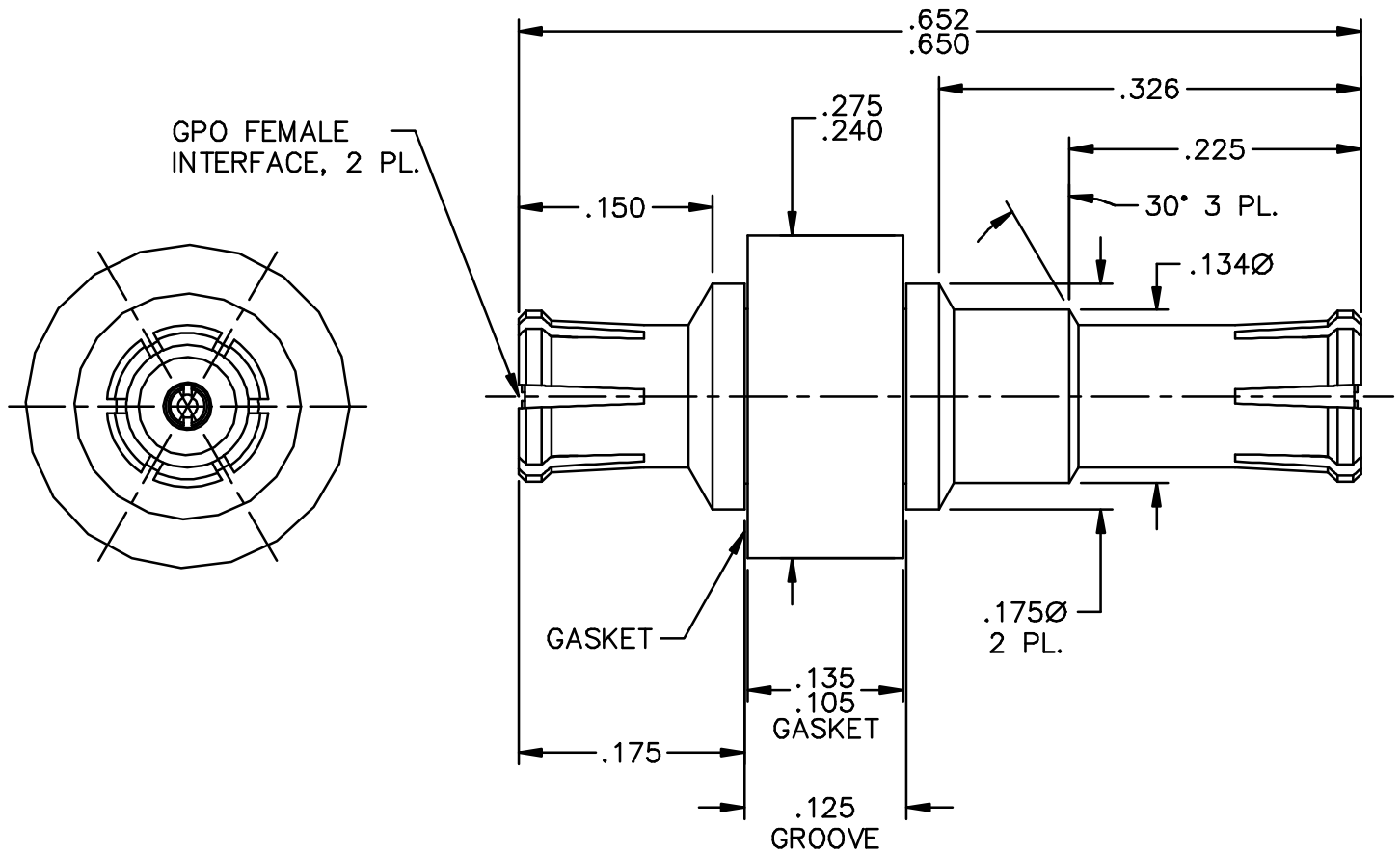
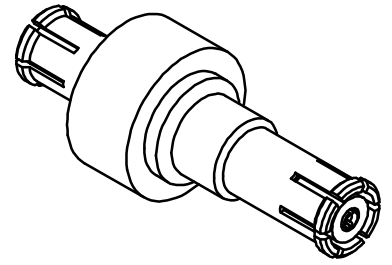
NEOPRENE SPONGE RUBBER
HARDNESS: 30-50, SHORE 00

TOLERANCES

.XX .010

.XXX .005

This drawing and any data contained herein is the property of Corning Gilbert Inc., and constitutes and contains proprietary and confidential information. Neither receipt nor possession of this drawing confers or transfers any right to duplicate, use or disclose any information contained herein except as expressly authorized by Corning Gilbert Inc.

GPO BLINDMATE
INTERCONNECT
(.651 LONG)

IDENT CODE:
82316

REVISION: C

Corning Gilbert Inc.

SOURCE FILE: SK-2407

DWG. NO.: OL-A1A1-0001-24

ASSY. PROC.: -