

CATALOG NUMBER

1B6A3-1543-01

MATERIAL AND FINISH

GPPO SHROUD AND
SPRING SLEEVE:

CENTER CONTACT, GPO
SHROUD, AND SNAP RING:

DIELECTRICS:

SPRING:

CRES 303; PASSIVATED

BeCu; GOLD PLATE 50-100 MICROINCHES
OVER NICKEL PLATE 50 MICROINCHES MIN.

VIRGIN PTFE

STAINLESS STEEL 17-7 PH CONDITION CH900

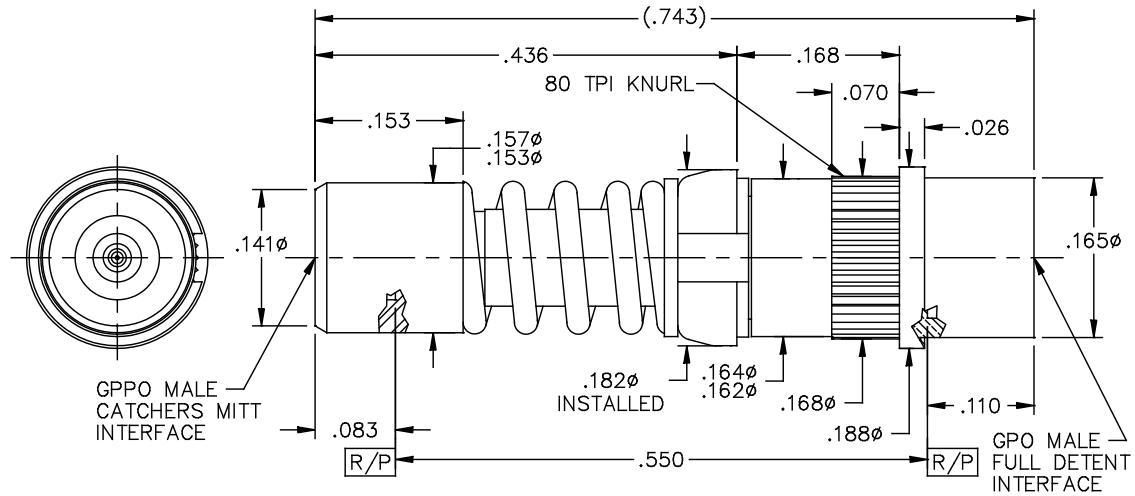
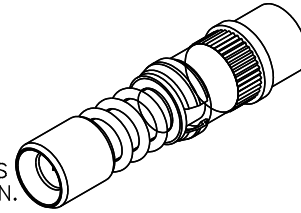

RECOMMENDED
MOUNTING HOLE

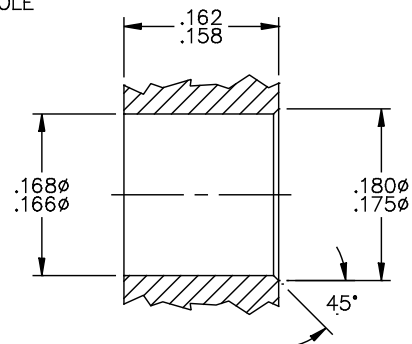

This drawing and any data contained herein is the property of Corning Gilbert Inc., and constitutes and contains proprietary and confidential information. Neither receipt nor possession of this drawing confers or transfers any right to duplicate, use or disclose any information contained herein except as expressly authorized by Corning Gilbert Inc.

GPPO MALE CATCHERS MITT
SNAP-IN FLOAT MOUNT TO
GPO MALE FULL DETENT

IDENT CODE:

82316

REVISION: B

Corning Gilbert Inc.

SOURCE FILE: MECR# 2880

DWG. NO.: OL-1B6A3-1543-01

ASSY. PROC.: -