

NOTE: Information herein is believed by Southwest Microwave, Inc. to be accurate. However, Southwest Microwave assumes no responsibility for any omissions or errors or inaccuracies for its use or for any infringements of patents or other rights of third parties that may result from its use. Data is intended for informational purpose only and does not constitute a contract of sale or any express or implied warranty, including any warranty of merchant ability or fitness for a particular purpose.

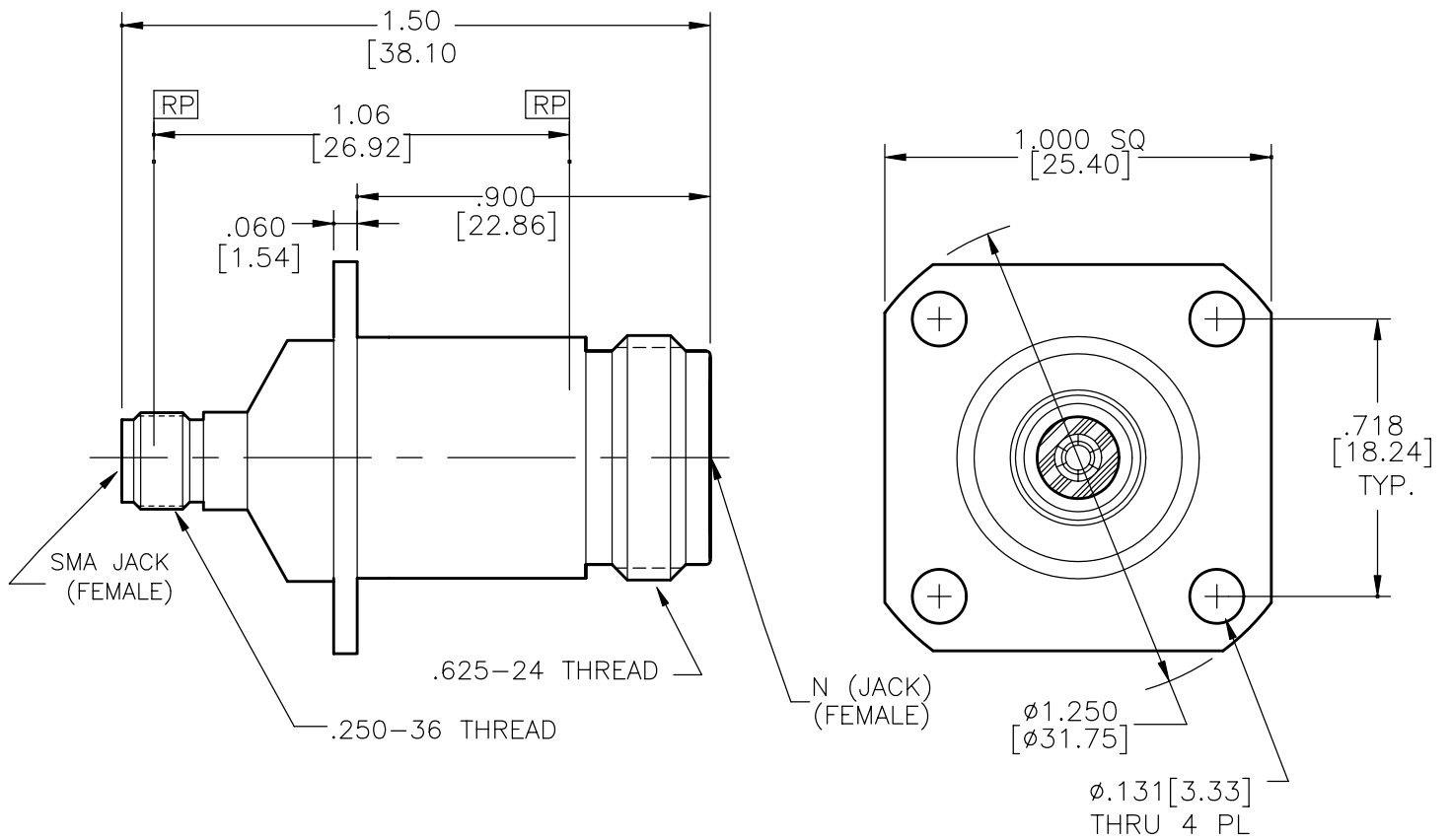

HOUSING:	STEEL, CRES ALLOY UNS-S30300 PER ASTM-A582. PASSIVATE PER ASTM-A967-99
CONTACT:	BeCu UNS-C17300 PER ASTM-B-196/197 GOLD PLATE PER MIL-G-45204
DIELECTRIC:	VIRGIN TFE FLUOROCARBON PER ASTM-D-1710 AND ASTM-D-1457
BEAD RING:	ULTEM 1000 PER ASTM-D-5205
ITEM	MATERIAL & FINISH

2. INTERFACE I.A.W. MIL-STD-348

1. ALL DIMENSIONS ARE IN INCHES, ALL ANGLES ARE IN DEGREES. DIMENSIONS SHOWN IN BRACKETS [XXX] ARE MILLIMETERS.

TOLERANCES ARE BASED UPON DIMENSIONS IN INCHES. METRIC DIMENSIONS ARE FOR "REFERENCE ONLY".

NOTES: UNLESS OTHERWISE SPECIFIED

CONTACT GAGING SPEC.	91B52114
CONTACT GAGING SPEC.	91C54030
SPECIFICATIONS	91Y54479
SPECIFICATION GROUP	DRAWING NO.

REV A	RELEASE	DATE: 9/12/06	APRVD. SS	DATE: 12/4/06
-------	---------	---------------	-----------	---------------



Southwest Microwave, Inc.
 9055 South McKemy Street
 Tempe, Arizona 85284-2946
 Telephone (480) 783-0201
 Fax (480) 783-0360

TITLE		SMA JACK TO N JACK 4 HOLE 1.0SQ FLG BULKHEAD ADAPTER	
DRN BY: SS	DATE: 9/06	MODEL NO.	2312SF
SCALE: 3:1		DWG. NO.	79Y59116
SHEET: 1 OF 1		REV.	A

O.L.-A-303 REV D