

ENVELOPE / ASSEMBLY DRAWING

00000

SPECIFICATION CONTROL DRAWING

THIS DRAWING CONTAINS INFORMATION PROPRIETARY TO RF INDUSTRIES, LTD. ANY UNAUTHORIZED USE OF THIS DRAWING IS EXPRESSLY PROHIBITED. ANY VIOLATION IS PUNISHABLE UNDER U.S. COPYRIGHT LAWS.

REV	DESCRIPTION	DWN	DATE	APPROVED
A2	ADD GRND RING, GASKET & DIE DETAIL [DWG #8008]	KMM	2/8/93	J. BENZ
A3	STANDARDIZE	KMM	2/23/93	J. BENZ
B	PROVIDE MISSING DIMENSIONS	KMM	1/30/96	R. RICE
C	CHANGE SHELL DIMS / CHANGE BODY FOR NEW SHELL DIM	CZS	2/23/99	R. RICE

ALL DIMENSIONS ARE REFERENCE ONLY

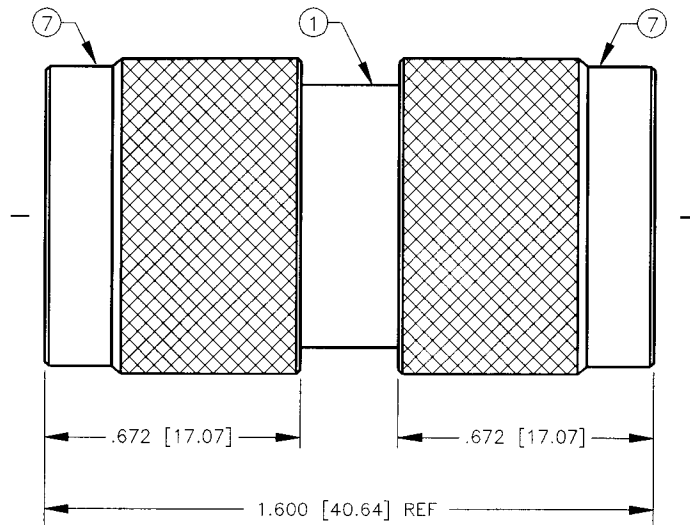

SPECIFICATIONS:

IMPEDANCE: 50 OHMS
 WORKING VOLTAGE: 1000 VRMS @ SEA LEVEL
 FREQUENCY RANGE: 0-11 GHz
 INTERFACE PER MIL-STD-348A, SECTION 304.1
 BODY MUST CAPTIVATE DIELECTRIC SECURELY
 DIELECTRIC MUST CAPTIVATE CONTACT SECURELY
 GOLD FINISH: 3 MICROINCHES OVER BRASS
 SILVER FINISH: 30 MICROINCHES OVER BRASS
 SUBSTITUTIONS NOT ACCEPTED WITHOUT PRIOR APPROVAL FROM RFI
 KNURL: FULL RAISED 30P MEDIUM DIAMOND KNURL
 REMOVE ALL BURRS & BREAK ALL SHARP EDGES
 ALL CORNERS TO BE .010 R MAX
 ALL DIAMETERS TO BE CONCENTRIC WITHIN .005

DIMENSIONS ARE IN INCHES AND [MILLIMETERS]

UNLESS OTHERWISE NOTED TOLERANCES ARE:
DECIMALS DIAMETER

RF connectors
DIVISION OF RF INDUSTRIES, LTD.

7610 MIRAMAR RD
SAN DIEGO, CA 92126
(619)549-6340
(619)549-6345 FAX

RFN-1014-1

N MALE TO N MALE BARREL ADAPTER

ITEM	DESCRIPTION	QTY	MATERIAL	FINISH
7	SHELL	2	BRASS	SILVER
6	PRESS FIT GND RING	1	BRASS	SILVER
5	GASKET	2	S.I. RUBBER	RED
4	RETAINING RING	2	BRASS	SILVER
3	DIELECTRIC	2	TEFLON	NONE
2	PIN	1	BRASS	GOLD
1	BODY	1	BRASS	SILVER

DRAWN C. ZUNIGA	2/23/99
CHECKED <i>C. Zuniga</i>	2/24/99
ORD. DRAWN D. FRIAS	3/3/88
APPROVALS	DATE

SIZE A	CABLE GROUP N/A	DWG NO. 8008	REV C
SCALE: 2:1	CAD FILE 13ARC B	SHEET 1 OF 1	