

CAD DRAWING - NO MANUAL REVISIONS

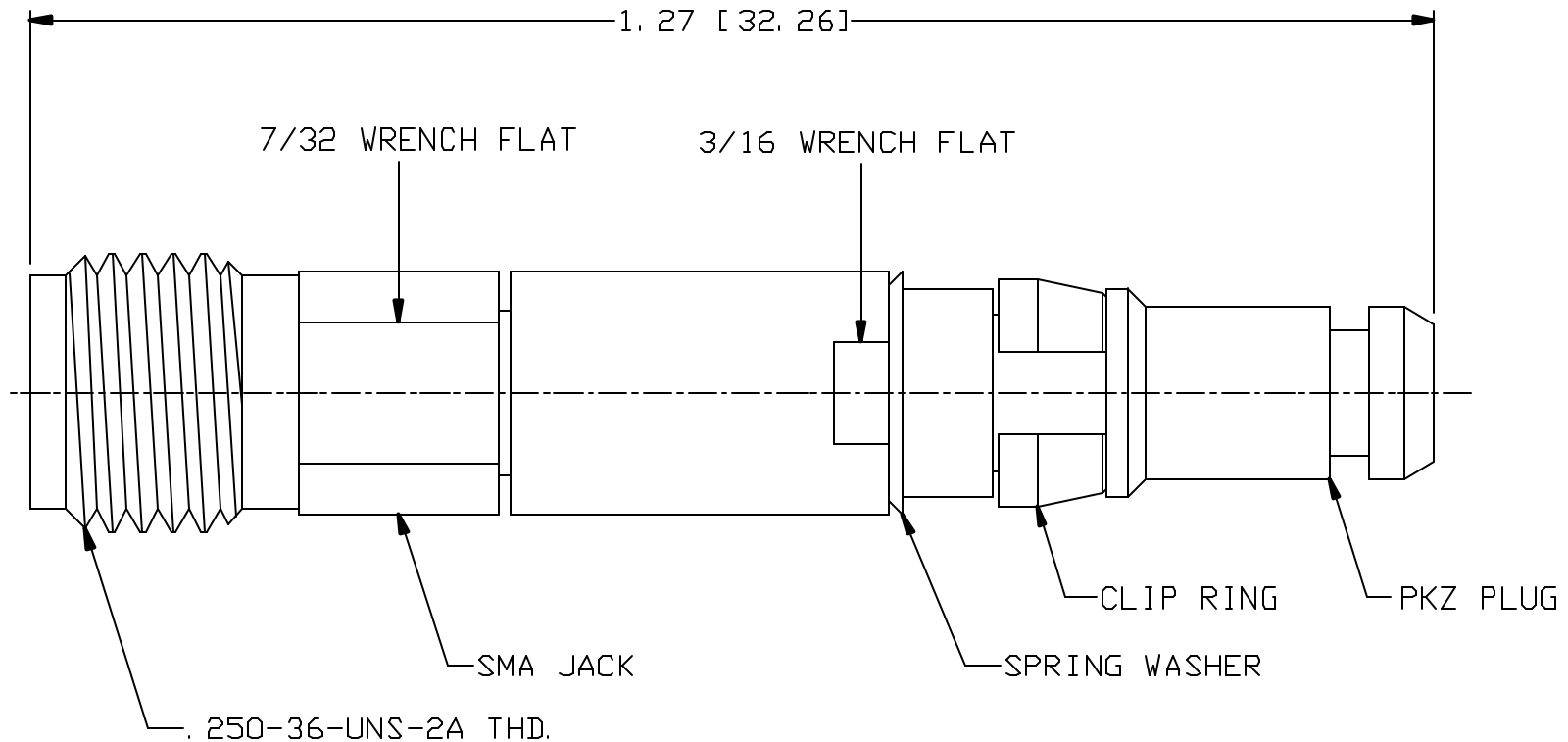

NOTE:

1. FOR USE TO 2 GHZ MAX.
2. DESIGN AND INTERFACE PER I. D. S. 26 & 20.

M	PER ECN 10661	10/25/10	JEM	PALCO CONNECTOR 22 GREAT HILL RD., NAUGATUCK, CT 06770 UNLESS OTHERWISE SPECIFIED, PALCO WORKMANSHIP STANDARDS APPLY TOLERANCES ON: DECIMALS: XX ± .01 .XXX ± .005 ANGLES ± 1/2° 32' DIMENSIONS IN INCHES OR (METRIC) DO NOT SCALE PRINTS	DRAWN MY	CHECKED HN	ENGINEER EW	APPROVED HN	FSCM 58167
L	PER ECN 10588	09/01/10	JEM			DESCRIPTION SMA, PKZ ADAPTOR			
K	PER ECN 10381	05/19/10	JEM			DATE 06/01/90	DRAWING NO. 2620-0100-00	PLATING OPT. G	
H	PER ECN 10235	03/16/10	JEM						
G	PER ECN 9489	08/20/08	JEM						
REV.	DESCRIPTION	DATE	APPR.	CATALOG ITEM					