

REVISIONS			
REV	DESCRIPTION	DATE	APPROVED
-	INITIAL RELEASE	07/12/00	A.M.
A	ECO #3865	11/13/00	A.M.

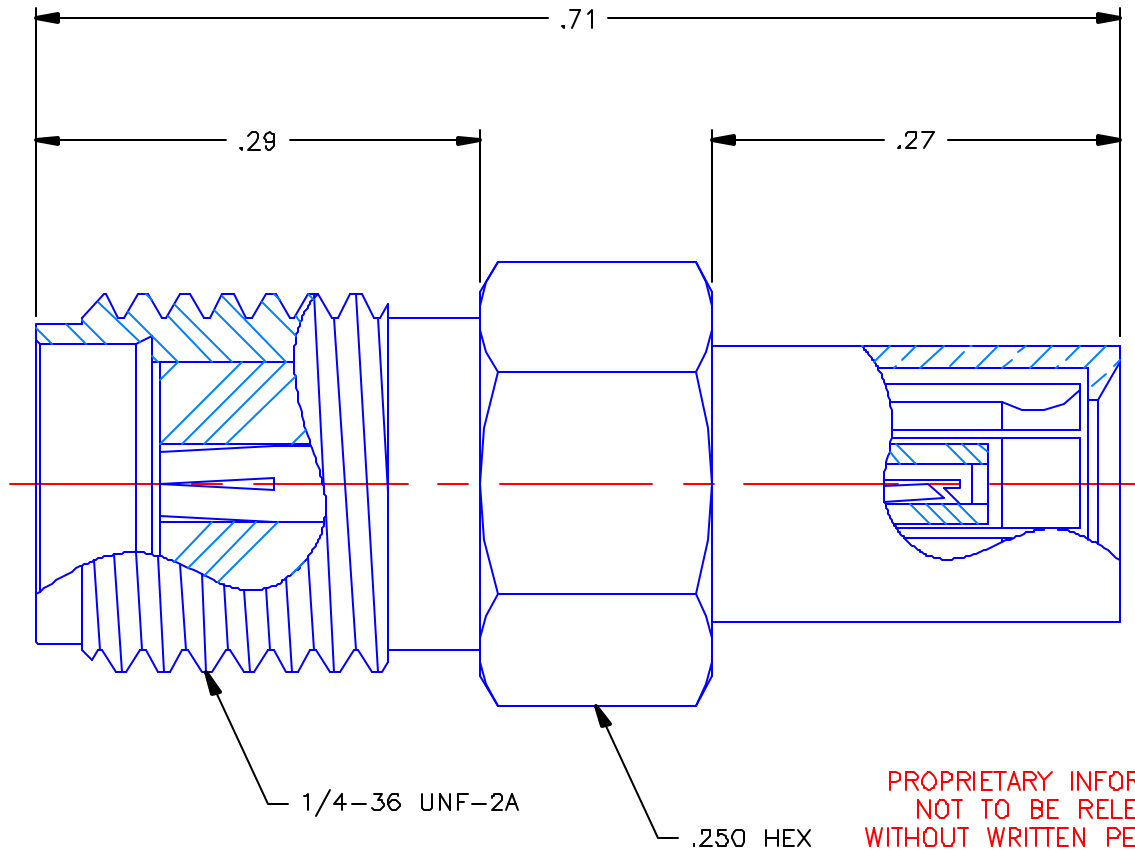

PROPRIETARY INFORMATION  
NOT TO BE RELEASED  
WITHOUT WRITTEN PERMISSION  
FROM AN AUTHORIZED  
REPRESENTATIVE OF  
APPLIED ENGINEERING PRODUCTS

NOTES:

MATERIALS:

1. BODY = STAINLESS STEEL PER ASTM A582, ALLOY 303, CONDITION "A".
2. CONTACT = BERYLLIUM COPPER PER ASTM B196, ALLOY C17300, TEMPER TD04.
3. INSULATOR = VIRGIN WHITE TEFLON PER ASTM D1710, GRADE 1, TYPE I, CLASS "A".
4. SLEEVE = BRASS PER ASTM B16, ALLOY C36000, TEMPER H02.

FINISHES:

1. BODY & SLEEVE = GOLD PLATE PER MIL-G-45204, TYPE II, CLASS 0, GRADE C, OVER .00010 TO .00020 COPPER STRIKE PER MIL-C-14550.
2. CONTACT = GOLD PLATE PER MIL-G-45204, TYPE II, CLASS 1, GRADE C, OVER .00010 TO .00020 STRESS FREE SULFAMATE NICKEL PER QQ-N-290.

UNLESS OTHERWISE SPECIFIED DIMENSIONS ARE IN INCHES TOLERANCES ON		DWN: A.M.	DATE 07/12/00	 <b>APPLIED ENGINEERING PRODUCTS</b> 104 John W. Murphy Dr. New Haven, CT 06513
		CHKD: D.N.	DATE 07/12/00	
DECIMAL	ANGLE	APVD: D.J.C.	DATE 07/12/00	<b>SMA JACK TO SSMB FEMALE PLUG ADAPTER</b>
REFERENCE:	MATERIALS & FINISHES:  SEE NOTES	SIZE A	FSCM NO. 19505	
ORIGINATOR: A.M. DATE: 07/12/00			SCALE 8:1	REV A
				SHEET 1 OF 1

5942-1503-000