

SPECIFICATION CONTROL DRAWING

THIS DRAWING CONTAINS INFORMATION PROPRIETARY TO RF INDUSTRIES, LTD. ANY UNAUTHORIZED USE OF THIS DRAWING IS EXPRESSLY PROHIBITED. ANY VIOLATION IS PUNISHABLE UNDER U.S. COPYRIGHT LAWS.

REV	DESCRIPTION
A	ENGINEERING RELEASE
B	CREATE SECTION DRAWING
C	CHANGE & ADD PIN, CONTACT, BODY & PRESS-FIT BODY

ALL DIMENSIONS ARE REFERENCE ONLY

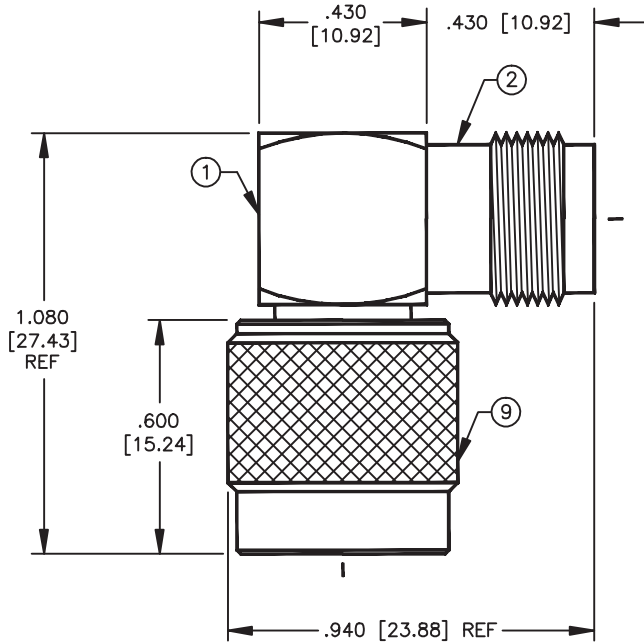

SPECIFICATIONS:

IMPEDANCE: 50 OHMS
 WORKING VOLTAGE: 500 VRMS @ SEA LEVEL
 FREQUENCY RANGE: 0-7 GHz

ITEM	DESCRIPTION	QTY	MATERIAL	FINISH
9	SHELL	1	BRASS	NICKEL
8	RETAINING RING	1	BRASS	NONE
7	GASKET	1	S.I. RUBBER	RED
6	DIELECTRIC	1	PTFE	NONE
5	DIELECTRIC	1	PTFE	NONE
4	PIN	1	BRASS	GOLD
3	CONTACT	1	BRASS	GOLD
2	PRESS FIT BODY	1	BRASS	NICKEL
1	BODY	1	BRASS	NICKEL

DIMENSIONS ARE IN INCHES AND [MILLIMETERS]

UNLESS OTHERWISE NOTED TOLERANCES ARE:
 DECIMALS DIAMETER

DRAWN	C. ZUNIGA	9/21/98
CHECKED		
ORJ DRAWN	P. BREAUX	10/8/92
APPROVALS		DATE

RFconnect
 DIVISION OF RF INDUSTRIES

RFT-12

TNC MALE TO TNC

SIZE	CABLE GROUP	DWG NO.
A	N/A	
SCALE: 2:1		CAD FILE 13ARC