

# ENVELOPE / ASSEMBLY DRAWING

00000

## SPECIFICATION CONTROL DRAWING

THIS DRAWING CONTAINS INFORMATION PROPRIETARY TO RF INDUSTRIES, LTD. ANY UNAUTHORIZED USE OF THIS DRAWING IS EXPRESSLY PROHIBITED. ANY VIOLATION IS PUNISHABLE UNDER U.S. COPYRIGHT LAWS.

| REV | DESCRIPTION                          | DWN | DATE     | APPROVED   |
|-----|--------------------------------------|-----|----------|------------|
| A2  | CHG KNURL DIAMETER / RPLS DWG #7918  | DM  | 3/19/93  | C. JONES   |
| B   | STANDARDIZE                          | KMM | 11/19/97 | R. RICE    |
| C   | UPDATE TOLERANCES BLOCK / REMOVE P/N | CZS | 7/28/99  | R. RICE    |
| D   | CHANGE DIELECTRIC CONFIGURATION      | CZS | 2/18/00  | J. D. McR. |

ALL DIMENSIONS ARE REFERENCE ONLY

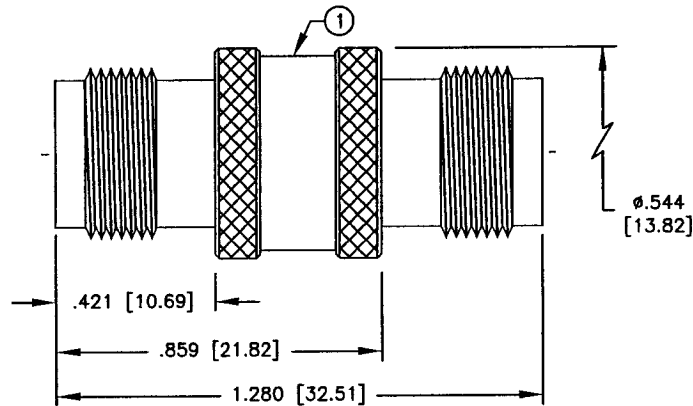

### SPECIFICATIONS:

IMPEDANCE: 50 OHMS  
 WORKING VOLTAGE: 500 VRMS @ SEA LEVEL  
 FREQUENCY RANGE: 0-12 GHz  
 INTERFACE PER MIL-STD-348, SECTION 313.2

DIMENSIONS ARE IN INCHES AND [MILLIMETERS]

UNLESS OTHERWISE NOTED TOLERANCES ARE:  
 DECIMALS DIAMETER

**RFconnectors**  
 DIVISION OF RF INDUSTRIES, LTD.

7610 MIRAMAR RD  
 SAN DIEGO, CA 92126  
 (858) 549-6340  
 (858) 549-6345 FAX

## RFT-1225

TNC FEMALE TO TNC FEMALE ADAPTER

| ITEM | DESCRIPTION      | QTY | MATERIAL | FINISH | APPROVALS              | DATE    | SCALE:     | CABLE GROUP      | DWG NO.      | REV |
|------|------------------|-----|----------|--------|------------------------|---------|------------|------------------|--------------|-----|
| 4    | PRESS FIT WASHER | 1   | BRASS    | NICKEL | DRAWN<br>C. ZUNIGA     | 2/18/00 | A          | N/A              | 8048         | D   |
| 3    | DIELECTRIC       | 2   | TEFLON   | NONE   | CHECKED<br>DMM         | 2-18-00 |            |                  |              |     |
| 2    | CONTACT          | 1   | BRASS    | GOLD   | ORJ DRAWN<br>D. MORRIS | 2/2/93  |            |                  |              |     |
| 1    | BODY             | 1   | BRASS    | NICKEL |                        |         |            |                  |              |     |
|      |                  |     |          |        |                        |         | SCALE: 2:1 | CAD FILE 13ARC B | SHEET 1 OF 1 |     |