

Coaxial Assemblies



**ARMORED
WORKHORSE**

Next generation Armored WorkHorse® test assemblies

INTRODUCTION

The next generation of Armored WorkHorse® coaxial assemblies is a proven and cost effective group of test assemblies. These ruggedized test cables were specifically designed for use in high volume production environments, where strenuous flexing and numerous mating cycles quickly destroy typical connectors and attachment methods.

Carlisle Interconnect Technologies' (CarlisleIT) new Armored WorkHorse® assemblies are ideal replacements for OEM test port cables due to their long life and repeatable performance. Armored WorkHorse® assemblies utilize CarlisleIT's proven "544" triple shielded and "564" double shielded cables. Using a solid center conductor, these cables have excellent phase stability with flexure and performance up to 18 GHz.

FEATURES

- » DC to 18 GHz
- » Durable construction and attachment method
- » Crush-resistant spiral stainless steel armor
- » Phase stable with flexure for testing repeatability
- » "544" triple shielded and "564" double shielded for reduced leakage
- » RoHS compliant



Armored WorkHorse® Cables

18 GHz Armored WorkHorse® Test Assemblies

18 GHz Armored WorkHorse® Cable

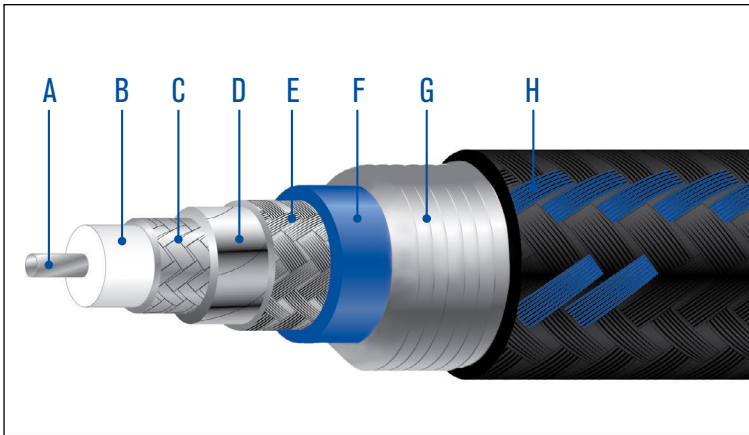

Uses 544 Cable - Triple Shielded		
Item	Material	Size
A. CENTER CONDUCTOR:	SILVER PLATED COPPER WELD STEEL	0.037 in.
B. DIELECTRIC:	SOLID PTFE	0.117 in.
C. INNER BRAID:	FLAT SILVER PLATED COPPER STRIP BRAID	0.127 in.
D. INTERLAYER:	ALUMINUM / POLYESTER FOIL	0.134 in.
E. OUTER BRAID:	SILVER PLATED COPPER WIRE	0.154 in.
F. JACKET:	BLUE TINT FEP	0.195 in.
G. ARMOR:	STAINLESS STEEL	N/A
H. MESH:	PET	N/A

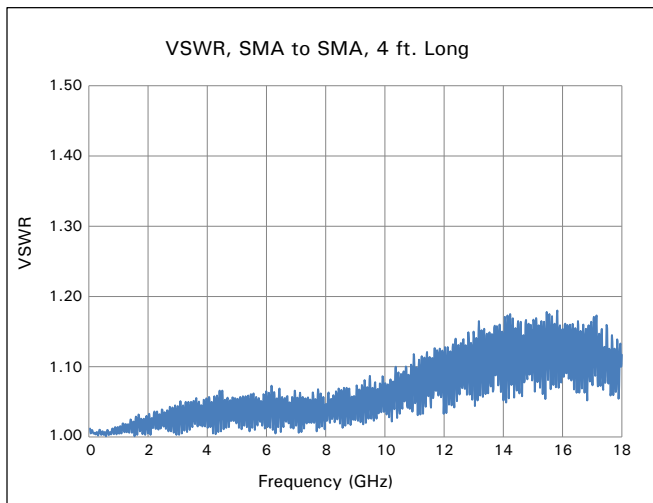
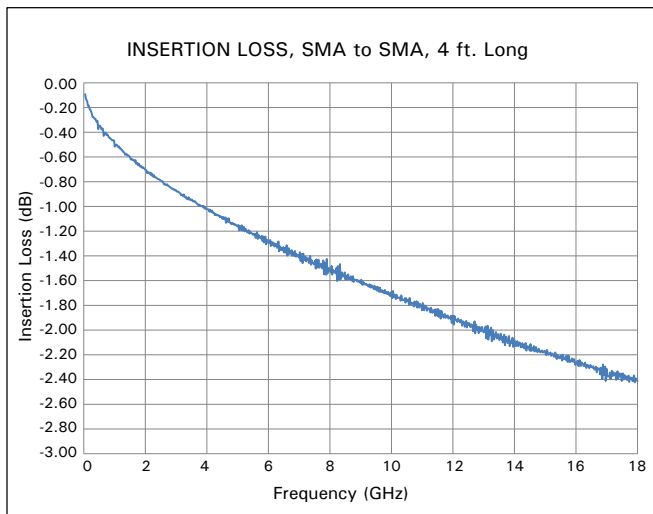

Mechanical Specifications	
CABLE MAXIMUM OUTER DIAMETER:	0.200 in.
OUTER CONDUCTOR INTEGRITY:	60 lbs. MIN. AXIAL PULL
MINIMUM BEND RADIUS:	3 in.
PREFERRED BEND RADIUS:	3.90 in.
TEMPERATURE RANGE:	-55 to +200°C
WEIGHT MAXIMUM:	0.048 lbs./ft.

Electrical Specifications	
CENTER CONDUCTOR DC RESISTANCE, NOMINAL:	0.73 Ω /100 ft.
OUTER CONDUCTOR DC RESISTANCE, NOMINAL:	3.29 Ω /100 ft.
IMPEDANCE, NOMINAL:	50 Ω
CAPACITANCE, NOMINAL:	29.4 pf/ft.
INDUCTANCE, NOMINAL:	0.072 μ H/ft.
VELOCITY OF PROPAGATION, NOMINAL:	70.7%
ELECTRICAL DELAY, NOMINAL:	1.44 ns/ft.
MAXIMUM OPERATING VOLTAGE:	1879 VRMS
MAXIMUM CW POWER RATING:	72 WATTS AT 26.5 GHz
MAXIMUM RETURN LOSS:	-22 dB AT 26.5 GHz
MAXIMUM INSERTION LOSS:	88.7 dB/100 ft. AT 26.5 GHz
INSERTION LOSS, NOMINAL:	82.9 dB/100 ft. AT 26.5 GHz
RELATIVE SHIELDING:	-100 dB

18 GHz Type N Male to Type N Male Assembly

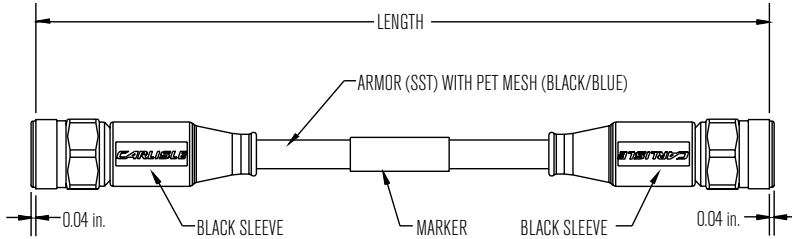

Materials and Finishes		
Description	Material	Finish or Color
CABLE JACKET:	LP-389 FEP	BLUE
MARKER:	MIL-I-23053	GREEN
BOOTS:	MIL-I-23053	BLACK
CONTACTS:	ASTM B196 BeCu	MIL-G-45204 GOLD PLATED
INSULATORS:	ASTM D1457 PTFE	NONE
TYPE N BODY:	ASTM A 582 303 STAINLESS STEEL	QQ-P-35 PASSIVATED
TYPE N NUT:	ASTM A 582 303 STAINLESS STEEL	QQ-P-35 PASSIVATED
ARMOR:	STAINLESS STEEL	NONE
MESH:	PET	BLACK/BLUE
THE TYPE N CONNECTOR DOES NOT HAVE A WEATHER SEALING GASKET.		
SOLVENTS:	NO OZONE DEPLETING MATERIALS ARE USED	

Electrical Specifications						
IMPEDANCE, NOMINAL:	50 Ω					
CAPACITANCE, NOMINAL:	29.4 pf/ft.					
VELOCITY OF PROPAGATION, NOMINAL:	70.7%					
RELATIVE SHIELDING:	-100.0 dB MIN.					
INSULATION RESISTANCE:	1000 M Ω MIN.					
DIELECTRIC WITHSTANDING VOLTAGE:	1500 VRMS MIN.					
ELECTRICAL DELAY, NOMINAL:	1.44 ns/ft.					
ELECTRICAL DELAY, NOMINAL:	120 ps/in.					
F (IN GHz) ----->	1	2	4	6	12	18
MAX. CW WATTS ----->	213	145	97	76	49	38
PHASE STABILITY DEG.	0.3	0.6	1.2	1.8	3.6	5.4
LOSS STABILITY dB --->	0.01	0.01	0.01	0.015	0.03	0.05
CABLE FORMED AND STRAIGHTENED 90 DEGREES ON A 4" RADIUS						

Mechanical Specifications	
CABLE MAX. DIAMETER:	0.200 in.
PREFERRED BEND RADIUS:	4.00 in.
CONNECTOR RETENTION:	100 lbs. MIN.
TEMPERATURE RANGE:	-55 to +105°C
MATING TORQUE:	7-10 in.-lbs.
TYPE N CONNECTOR INTERFACE:	MIL-STD-348 SOLID

Part Number	Length (Inches)	+ - Length	Weight (Ounces)	Maximum VSWR :1 at Frequency (in GHz)						Maximum Insertion Loss in dB/meter at Freq. (in GHz)						Length (CM)
				Up to 1	1 to 2	2 to 4	4 to 6	6 to 12	12 to 18	UP to 1	1 to 2	2 to 4	4 to 6	6 to 12	12 to 18	
WHE18-1818-018	18.0	0.20	4.9	1.07	1.12	1.15	1.18	1.22	1.30	0.26	0.37	0.54	0.68	1.01	1.32	45.7
WHE18-1818-020	20.0	0.20	5.0	1.07	1.12	1.15	1.18	1.22	1.30	0.28	0.40	0.59	0.73	1.10	1.43	50.8
WHE18-1818-024	24.0	0.24	5.3	1.07	1.12	1.15	1.18	1.22	1.30	0.32	0.46	0.68	0.85	1.28	1.66	61.0
WHE18-1818-030	30.0	0.30	5.6	1.07	1.12	1.15	1.18	1.22	1.30	0.39	0.55	0.81	1.02	1.54	2.00	76.2
WHE18-1818-036	36.0	0.36	5.9	1.07	1.12	1.15	1.18	1.22	1.30	0.45	0.64	0.95	1.19	1.80	2.35	91.4
WHE18-1818-040	40.0	0.40	6.2	1.07	1.12	1.15	1.18	1.22	1.30	0.49	0.70	1.03	1.30	1.98	2.57	101.6
WHE18-1818-048	48.0	0.48	6.6	1.07	1.12	1.15	1.18	1.22	1.30	0.57	0.82	1.21	1.53	2.33	3.03	121.9
WHE18-1818-060	60.0	0.60	7.3	1.07	1.12	1.15	1.18	1.22	1.30	0.69	1.00	1.48	1.87	2.85	3.71	152.4
WHE18-1818-072	72.0	0.72	8.0	1.07	1.12	1.15	1.18	1.22	1.30	0.81	1.18	1.75	2.21	3.38	4.40	182.9
WHE18-1818-080	80.0	0.80	8.5	1.07	1.12	1.15	1.18	1.22	1.30	0.89	1.30	1.93	2.44	3.73	4.86	203.2

MAXIMUM SPECIFICATIONS ARE PRODUCT MAXIMUM INCLUDING MEASURING SYSTEM UNCERTAINTY.

NOTE: PRODUCT SPECIFICATIONS ARE VERIFIED AT 22°C, SEA LEVEL AND 20 TO 80% RELATIVE HUMIDITY.

PRODUCT SPECIFICATIONS APPLY AT 5 TO 99% (NON CONDENSING) RELATIVE HUMIDITY, CONSULT FACTORY FOR PRODUCT CHARACTERISTICS AT OTHER CONDITIONS.

18 GHz Armored WorkHorse® Test Assemblies

18 GHz Type N Male to SMA Male Assembly

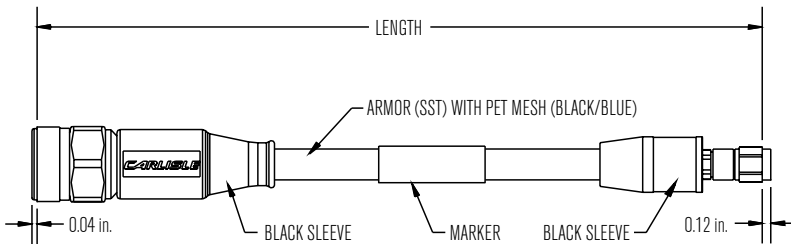

Electrical Specifications

IMPEDANCE, NOMINAL:	50 Ω					
CAPACITANCE, NOMINAL:	28.8 pf/ft.					
VELOCITY OF PROPAGATION, NOMINAL:	70.5%					
RELATIVE SHIELDING:	-100.0 dB MIN.					
INSULATION RESISTANCE:	1000 MΩ MIN.					
DIELECTRIC WITHSTANDING VOLTAGE:	1500 VRMS MIN.					
ELECTRICAL DELAY, NOMINAL:	1.44 ns/ft.					
ELECTRICAL DELAY, NOMINAL:	120 ps/in.					
F (IN GHz) ----->	1	2	4	6	12	18
MAX. CW WATTS ----->	360	245	164	129	84	64
PHASE STABILITY DEG.	0.3	0.6	1.2	1.8	3.6	5.4
LOSS STABILITY dB --->	0.01	0.01	0.01	0.015	0.03	0.05
CABLE FORMED AND STRAIGHTENED 90 DEGREES ON A 4" RADIUS						

Mechanical Specifications

CABLE MAX. DIAMETER:	0.200 in.
MIN. ONE TIME BEND RADIUS:	1.00 in.
PREFERRED BEND RADIUS:	4.00 in.
CONNECTOR RETENTION:	100 lbs. MIN.
TEMPERATURE RANGE:	-55 to +105°C
MATING TORQUE:	7-10 in.-lbs.
SMA CONNECTOR INTERFACES:	MIL-STD-348
TYPE N CONNECTOR INTERFACES:	MIL-STD-348 SOLID

Materials and Finishes		
Description	Material	Finish or Color
CABLE JACKET:	LP-389 FEP	BLUE
MARKER:	MIL-I-23053	WHITE
BOOTS:	MIL-I-23053	BLACK
CONTACTS:	ASTM B196 BeCu	MIL-G-45204 GOLD PLATED
INSULATORS:	ASTM D1710 PTFE	NONE
CONNECTOR BODIES:	ASTM A 582 303 STAINLESS STEEL	QQ-P-35 PASSIVATED
CONNECTOR NUTS:	ASTM A 582 303 STAINLESS STEEL	QQ-P-35 PASSIVATED
SMA GASKET:	ZZ-R-765 SILICONE RUBBER	NONE
ARMOR:	STAINLESS STEEL	NONE
MESH:	PET	BLACK/BLUE
THE TYPE N CONNECTOR DOES NOT HAVE A WEATHER SEALING GASKET.		
SOLVENTS:	NO OZONE DEPLETING MATERIALS ARE USED	

Part Number	Length (Inches)	+ - Length	Weight (Ounces)	Maximum VSWR :1 at Frequency (in GHz)						Maximum Insertion Loss in dB/meter at Freq. (in GHz)						Length (CM)
				Up to 1	1 to 2	2 to 4	4 to 6	6 to 12	12 to 18	UP to 1	1 to 2	2 to 4	4 to 6	6 to 12	12 to 18	
WHE18-1836-018	18.0	0.25	4.4	1.07	1.12	1.15	1.18	1.22	1.30	0.28	0.39	0.56	0.70	1.04	1.34	45.7
WHE18-1836-020	20.0	0.25	4.5	1.07	1.12	1.15	1.18	1.22	1.30	0.30	0.42	0.61	0.76	1.13	1.45	50.8
WHE18-1836-024	24.0	0.25	4.8	1.07	1.12	1.15	1.18	1.22	1.30	0.34	0.48	0.70	0.87	1.31	1.68	61.0
WHE18-1836-030	30.0	0.30	5.1	1.07	1.12	1.15	1.18	1.22	1.30	0.41	0.57	0.83	1.04	1.57	2.02	76.2
WHE18-1836-036	36.0	0.36	5.4	1.07	1.12	1.15	1.18	1.22	1.30	0.47	0.66	0.97	1.21	1.83	2.37	91.4
WHE18-1836-040	40.0	0.40	5.7	1.07	1.12	1.15	1.18	1.22	1.30	0.51	0.72	1.05	1.32	2.01	2.59	101.6
WHE18-1836-048	48.0	0.48	6.1	1.07	1.12	1.15	1.18	1.22	1.30	0.59	0.84	1.23	1.55	2.36	3.05	121.9
WHE18-1836-060	60.0	0.60	6.8	1.07	1.12	1.15	1.18	1.22	1.30	0.71	1.02	1.50	1.89	2.88	3.73	152.4
WHE18-1836-072	72.0	0.72	7.5	1.07	1.12	1.15	1.18	1.22	1.30	0.83	1.20	1.77	2.23	3.41	4.42	182.9
WHE18-1836-080	80.0	0.80	8.0	1.07	1.12	1.15	1.18	1.22	1.30	0.91	1.32	1.95	2.46	3.76	4.88	203.2

MAXIMUM SPECIFICATIONS ARE PRODUCT MAXIMUM PLUS MEASURING SYSTEM UNCERTAINTY

NOTE: PRODUCT SPECIFICATIONS ARE VERIFIED AT 22°C, SEA LEVEL AND 20 TO 80% RELATIVE HUMIDITY.

PRODUCT SPECIFICATIONS APPLY AT 5 TO 99% (NON CONDENSING) RELATIVE HUMIDITY, CONSULT FACTORY FOR PRODUCT CHARACTERISTICS AT OTHER CONDITIONS.

18 GHz SMA Male to SMA Male Assembly

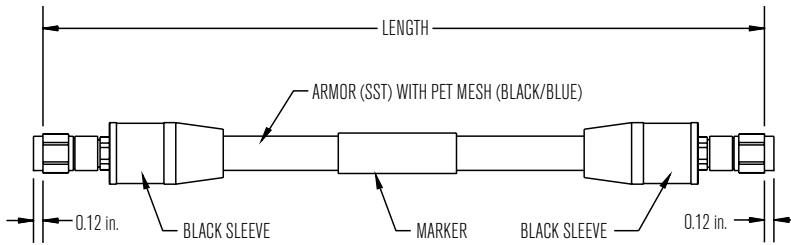

Electrical Specifications

IMPEDANCE, NOMINAL:	50 Ω
CAPACITANCE, NOMINAL:	28.8 pf/ft.
VELOCITY OF PROPAGATION, NOMINAL:	70.5%
RELATIVE SHIELDING:	> -100.0 dB MIN.
INSULATION RESISTANCE:	1000 M Ω MIN.
DIELECTRIC WITHSTANDING VOLTAGE:	1000 VRMS MIN.
ELECTRICAL DELAY, NOMINAL:	1.44 ns/ft.
ELECTRICAL DELAY, NOMINAL:	120 ps/in.
PULSE RF POWER:	1250 WATTS MAX.
(INTO A 50 OHM SYSTEM, WITH DUTY CYCLE LESS THAN CW RATING)	
F (IN GHz) ----->	1 2 4 6 12 18
MAX. CW WATTS ----->	213 145 97 76 49 38
PHASE STABILITY DEG. --->	0.3 0.6 1.2 1.8 3.6 5.4
LOSS STABILITY dB --->	0.01 0.01 0.01 0.02 0.03 0.05

Materials and Finishes

Description	Material	Finish or Color
CABLE JACKET:	LP-389 FEP	BLUE
MARKER:	MIL-I-23053	WHITE
BOOTS:	MIL-I-23053	BLACK
CONTACTS:	ASTM B196 BeCu	MIL-G-45204 GOLD PLATED
INSULATORS:	ASTM D1457 PTFE	NONE
CONNECTOR BODIES:	ASTM A 582 303 STAINLESS STEEL	QQ-P-35 PASSIVATED
CONNECTOR NUTS:	ASTM A 582 303 STAINLESS STEEL	QQ-P-35 PASSIVATED
GASKETS:	ZZ-R-765 SILICONE RUBBER	RED
ARMOR:	STAINLESS STEEL	NONE
MESH:	PET	BLACK/BLUE
SOLVENTS:	NO OZONE DEPLETING MATERIALS ARE USED	

Mechanical Specifications

CABLE MAX. DIAMETER:	0.200 in.
PREFERRED BEND RADIUS:	4.00 in.
CONNECTOR RETENTION:	75 lbs. MIN.
TEMPERATURE RANGE:	-55 to +105°C
MATING TORQUE:	7-10 in.-lbs.
CONNECTOR INTERFACES:	MIL-STD-348

Part Number	Length (Inches)	+ - Length	Weight (Ounces)	Maximum VSWR :1 at Frequency (in GHz)						Maximum Insertion Loss in dB/meter at Freq. (in GHz)						Length (CM)
				Up to 1	1 to 2	2 to 4	4 to 6	6 to 12	12 to 18	UP to 1	1 to 2	2 to 4	4 to 6	6 to 12	12 to 18	
WHE18-3636-018	18.0	0.18	3.3	1.07	1.12	1.15	1.18	1.22	1.30	0.26	0.36	0.52	0.65	0.97	1.25	45.7
WHE18-3636-020	20.0	0.20	3.4	1.07	1.12	1.15	1.18	1.22	1.30	0.28	0.39	0.57	0.70	1.06	1.37	50.8
WHE18-3636-024	24.0	0.24	3.7	1.07	1.12	1.15	1.18	1.22	1.30	0.32	0.45	0.66	0.82	1.24	1.60	61.0
WHE18-3636-030	30.0	0.30	4.0	1.07	1.12	1.15	1.18	1.22	1.30	0.39	0.54	0.79	0.99	1.50	1.94	76.2
WHE18-3636-036	36.0	0.36	4.3	1.07	1.12	1.15	1.18	1.22	1.30	0.45	0.63	0.93	1.16	1.76	2.28	91.4
WHE18-3636-040	40.0	0.40	4.6	1.07	1.12	1.15	1.18	1.22	1.30	0.49	0.69	1.01	1.27	1.94	2.51	101.6
WHE18-3636-048	48.0	0.48	5.0	1.07	1.12	1.15	1.18	1.22	1.30	0.57	0.81	1.19	1.50	2.29	2.97	121.9
WHE18-3636-060	60.0	0.60	5.7	1.07	1.12	1.15	1.18	1.22	1.30	0.69	0.99	1.46	1.84	2.82	3.65	152.4
WHE18-3636-072	72.0	0.72	6.4	1.07	1.12	1.15	1.18	1.22	1.30	0.81	1.17	1.73	2.19	3.34	4.33	182.9
WHE18-3636-080	80.0	0.80	6.9	1.07	1.12	1.15	1.18	1.22	1.30	0.89	1.29	1.91	2.41	3.69	4.79	203.2

MAXIMUM SPECIFICATIONS ARE PRODUCT MAXIMUM INCLUDING MEASURING SYSTEM UNCERTAINTY.

NOTE: PRODUCT SPECIFICATIONS ARE VERIFIED AT 22°C, SEA LEVEL AND 20 TO 80% RELATIVE HUMIDITY. SPECS FOR LENGTH OVER 240 INCHES ARE TYPICAL.

PRODUCT SPECIFICATIONS APPLY AT 5 TO 99% (NON CONDENSING) RELATIVE HUMIDITY, CONSULT FACTORY FOR PRODUCT CHARACTERISTICS AT OTHER CONDITIONS.

6 GHz Armored WorkHorse® Test Assemblies

6 GHz Armored WorkHorse® Cable

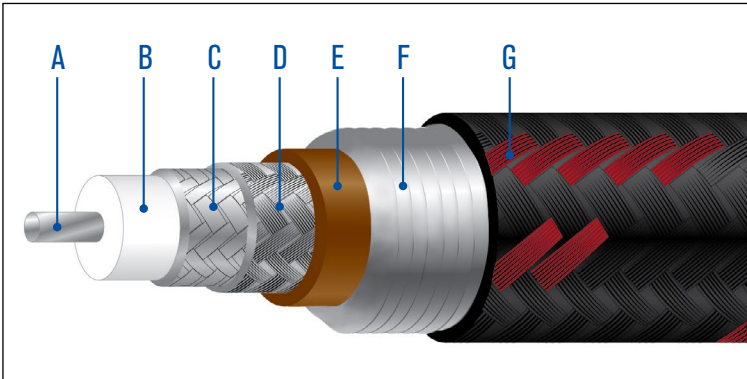

Uses 564 Cable - Double Shielded

Item	Material	Size
A. CENTER CONDUCTOR:	SILVER PLATED COPPER WELD STEEL	0.037 in.
B. DIELECTRIC:	SOLID PTFE	0.116 in.
C. INNER BRAID:	FLAT SILVER PLATED COPPER STRIP BRAID	0.137 in.
D. OUTER BRAID:	FLAT SILVER PLATED COPPER STRIP BRAID	0.171 in.
E. JACKET:	BROWN EXTRUDED FEP	0.195 in.
F. ARMOR:	STAINLESS STEEL	N/A
G. MESH:	PET	N/A

INSERTION LOSS, SMA to SMA, 3 ft. Long

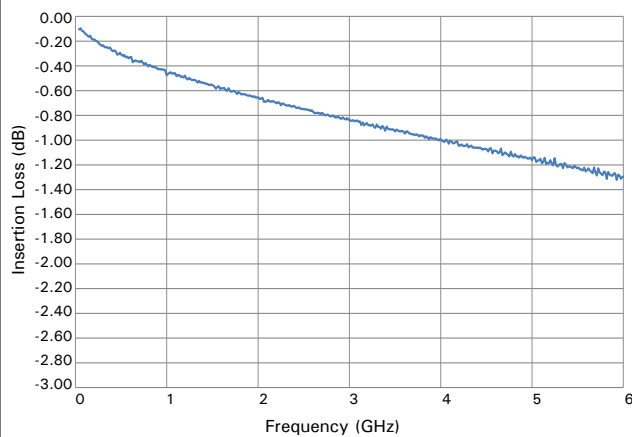

VSWR, SMA to SMA, 3 ft. Long

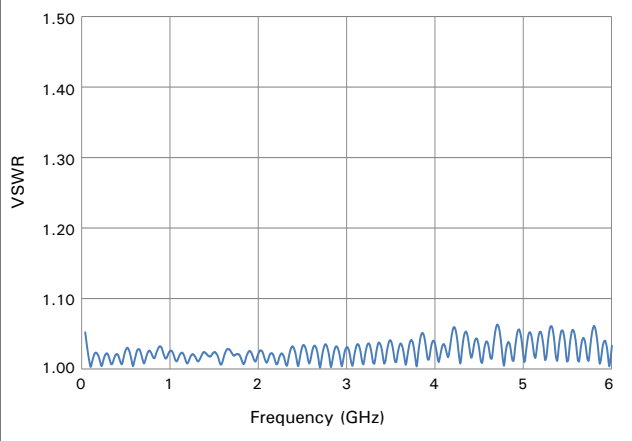

Mechanical Specifications

CABLE MAXIMUM OUTER DIAMETER:	0.200 in.
MINIMUM BEND RADIUS:	3.0 in.
PREFERRED BEND RADIUS:	3.90 in.
TEMPERATURE RANGE:	-55 to +200°C
WEIGHT MAXIMUM:	0.043 lbs./ft.

Electrical Specifications

CENTER CONDUCTOR DC RESISTANCE, NOMINAL:	1.95 Ω /100 ft.
IMPEDANCE, NOMINAL:	50 Ω
CAPACITANCE, NOMINAL:	29.3 pf/ft.
VELOCITY OF PROPAGATION, NOMINAL:	70.6%
MAXIMUM OPERATING VOLTAGE:	1400 VRMS
MAXIMUM CW POWER RATING:	600 WATTS AT 1 GHz
MAXIMUM RETURN LOSS:	-20 dB AT 12.4 GHz
MAXIMUM INSERTION LOSS:	85.4 dB/100 ft. AT 12.4 GHz
INSERTION LOSS, NOMINAL:	62.7 dB/100 ft. AT 12.4 GHz
RELATIVE SHIELDING:	-100 dB

6 GHz Type N Male to Type N Male Assembly

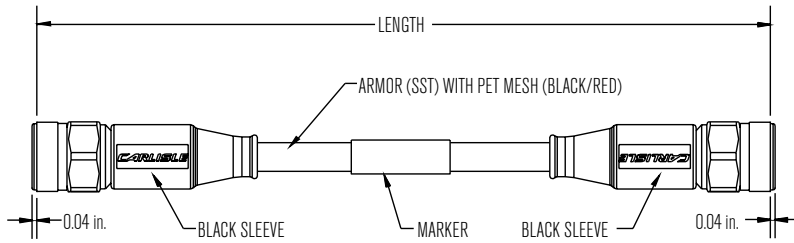

Materials and Finishes		
Description	Material	Finish or Color
CABLE JACKET:	LP-389 FEP	BROWN
MARKER:	MIL-I-23053	WHITE
BOOTS:	MIL-I-23053	BLACK
CONTACTS:	ASTM B196 BeCu	MIL-G-45204 GOLD PLATED
INSULATORS:	ASTM D1457 PTFE	NONE
TYPE N BODY:	ASTM A 582 303 STAINLESS STEEL	QQ-P-35 PASSIVATED
TYPE N NUT:	ASTM A 582 303 STAINLESS STEEL	QQ-P-35 PASSIVATED
ARMOR:	STAINLESS STEEL	NONE
MESH:	PET	BLACK/RED
THE TYPE N CONNECTOR DOES NOT HAVE A WEATHER SEALING GASKET.		
SOLVENTS:	NO OZONE DEPLETING MATERIALS ARE USED	

Electrical Specifications				
IMPEDANCE, NOMINAL:	50 Ω			
CAPACITANCE, NOMINAL:	29.3 pF/ft.			
VELOCITY OF PROPAGATION, NOMINAL:	70.6%			
RELATIVE SHIELDING:	-100.0 dB MIN.			
INSULATION RESISTANCE:	1000 MΩ MIN.			
DIELECTRIC WITHSTANDING VOLTAGE:	1400 VRMS MIN.			
ELECTRICAL DELAY, NOMINAL:	N/A			
ELECTRICAL DELAY, NOMINAL:	N/A			
F (IN GHz) ----->	1	2	4	6
MAX. CW WATTS ----->	600	400	300	200
PHASE STABILITY DEG.	N/A	N/A	N/A	N/A
LOSS STABILITY dB --->	0.03	0.03	0.03	0.04
CABLE FORMED AND STRAIGHTENED 90 DEGREES ON A 4" RADIUS				

Mechanical Specifications	
CABLE MAX. DIAMETER:	0.200 in.
PREFERRED BEND RADIUS:	3.90 in.
CONNECTOR RETENTION:	100 lbs. MIN.
TEMPERATURE RANGE:	-55 to +105°C
MATING TORQUE:	7-10 in.-lbs.
TYPE N CONNECTOR INTERFACE:	MIL-STD-348 SOLID

Part Number	Length (Inches)	+ - Length	Weight (Ounces)	Maximum VSWR :1 at Frequency (in GHz)					Maximum Insertion Loss in dB/meter at Freq. (in GHz)					Length (CM)
				Up to 1	1 to 2	2 to 4	4 to 6	6 to 12	UP to 1	1 to 2	2 to 4	4 to 6	6 to 12	
WHE06-1818-018	18.0	0.20	4.9	1.07	1.15	1.20	1.25	1.30	0.42	0.53	0.80	1.04	1.43	45.7
WHE06-1818-020	20.0	0.20	5.0	1.07	1.15	1.20	1.25	1.30	0.44	0.56	0.84	1.10	1.53	50.8
WHE06-1818-024	24.0	0.24	5.3	1.07	1.15	1.20	1.25	1.30	0.48	0.63	0.94	1.23	1.73	61.0
WHE06-1818-030	30.0	0.30	5.6	1.07	1.15	1.20	1.25	1.30	0.54	0.72	1.09	1.42	2.03	76.2
WHE06-1818-036	36.0	0.36	5.9	1.07	1.15	1.20	1.25	1.30	0.61	0.82	1.23	1.60	2.33	91.4
WHE06-1818-040	40.0	0.40	6.2	1.07	1.15	1.20	1.25	1.30	0.65	0.88	1.33	1.73	2.54	101.6
WHE06-1818-048	48.0	0.48	6.6	1.07	1.15	1.20	1.25	1.30	0.73	1.00	1.52	1.98	2.94	121.9
WHE06-1818-060	60.0	0.60	7.3	1.07	1.15	1.20	1.25	1.30	0.86	1.19	1.81	2.36	3.54	152.4
WHE06-1818-072	72.0	0.72	8.0	1.07	1.15	1.20	1.25	1.30	0.98	1.38	2.10	2.74	4.15	182.9
WHE06-1818-080	80.0	0.80	8.5	1.07	1.15	1.20	1.25	1.30	1.06	1.51	2.29	2.99	4.55	203.2

MAXIMUM SPECIFICATIONS ARE PRODUCT MAXIMUM INCLUDING MEASURING SYSTEM UNCERTAINTY.

NOTE: PRODUCT SPECIFICATIONS ARE VERIFIED AT 22°C, SEA LEVEL AND 20 TO 80% RELATIVE HUMIDITY.

PRODUCT SPECIFICATIONS APPLY AT 5 TO 99% (NON CONDENSING) RELATIVE HUMIDITY, CONSULT FACTORY FOR PRODUCT CHARACTERISTICS AT OTHER CONDITIONS.

6 GHz Armored WorkHorse® Test Assemblies

6 GHz Type N Male to SMA Male Assembly

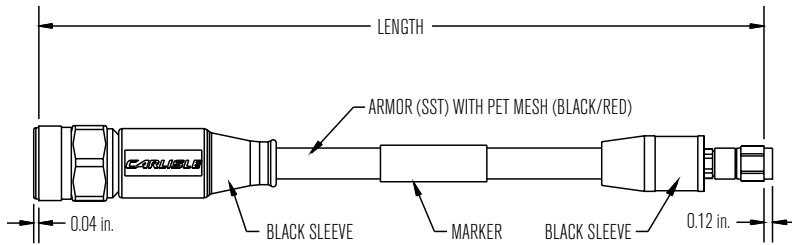

Materials and Finishes		
Description	Material	Finish or Color
CABLE JACKET:	LP-389 FEP	BLUE
MARKER:	MIL-I-23053	WHITE
BOOTS:	MIL-I-23053	BLACK
CONTACTS:	ASTM B196 BeCu	MIL-G-45204 GOLD PLATED
INSULATORS:	ASTM D1710 PTFE	NONE
CONNECTOR BODIES:	ASTM A 582 303 STAINLESS STEEL	QQ-P-35 PASSIVATED
CONNECTOR NUTS:	ASTM A 582 303 STAINLESS STEEL	QQ-P-35 PASSIVATED
SMA GASKET:	ZZ-R-765 SILICONE RUBBER	NONE
ARMOR:	STAINLESS STEEL	NONE
MESH:	PET	BLACK/RED
THE TYPE N CONNECTOR DOES NOT HAVE A WEATHER SEALING GASKET.		
SOLVENTS:	NO OZONE DEPLETING MATERIALS ARE USED	

Electrical Specifications				
IMPEDANCE, NOMINAL:	50 Ω			
CAPACITANCE, NOMINAL:	29.3 pf/ft.			
VELOCITY OF PROPAGATION, NOMINAL:	69.5%			
RELATIVE SHIELDING:	-100.0 dB MIN.			
INSULATION RESISTANCE:	100 MΩ MIN.			
DIELECTRIC WITHSTANDING VOLTAGE:	1400 VRMS MIN.			
ELECTRICAL DELAY, NOMINAL:	N/A			
ELECTRICAL DELAY, NOMINAL:	N/A			
F (IN GHz) ----->	1	2	4	6
MAX. CW WATTS ----->	600	400	300	200
PHASE STABILITY DEG.	N/A	N/A	N/A	N/A
LOSS STABILITY dB --->	0.03	0.03	0.03	0.04
CABLE FORMED AND STRAIGHTENED 90 DEGREES ON A 4" RADIUS				

Mechanical Specifications	
CABLE MAX. DIAMETER:	0.200 in.
MIN. ONE TIME BEND RADIUS:	1.17 in.
PREFERRED BEND RADIUS:	3.90 in.
CONNECTOR RETENTION:	100 lbs. MIN.
TEMPERATURE RANGE:	-55 to +105°C
MATING TORQUE:	7-10 in.-lbs.
SMA CONNECTOR INTERFACES:	MIL-STD-348
TYPE N CONNECTOR INTERFACES:	MIL-STD-348 SOLID

Part Number	Length (Inches)	+ - Length	Weight (Ounces)	Maximum VSWR :1 at Frequency (in GHz)					Maximum Insertion Loss in dB/meter at Freq. (in GHz)					Length (CM)
				Up to 1	1 to 2	2 to 4	4 to 6	6 to 12	UP to 1	1 to 2	2 to 4	4 to 6	6 to 12	
WHE06-1836-018	18.0	0.25	4.4	1.07	1.15	1.20	1.25	1.30	0.32	0.45	0.68	0.87	1.31	45.7
WHE06-1836-020	20.0	0.25	4.5	1.07	1.15	1.20	1.25	1.30	0.30	0.42	0.73	0.93	1.41	50.8
WHE06-1836-024	24.0	0.25	4.8	1.07	1.15	1.20	1.25	1.30	0.38	0.55	0.82	1.06	1.61	61.0
WHE06-1836-030	30.0	0.30	5.1	1.07	1.15	1.20	1.25	1.30	0.44	0.64	0.97	1.25	1.91	76.2
WHE06-1836-036	36.0	0.36	5.4	1.07	1.15	1.20	1.25	1.30	0.51	0.74	1.11	1.43	2.21	91.4
WHE06-1836-040	40.0	0.40	5.7	1.07	1.15	1.20	1.25	1.30	0.55	0.80	1.21	1.56	2.42	101.6
WHE06-1836-048	48.0	0.48	6.1	1.07	1.15	1.20	1.25	1.30	0.63	0.92	1.40	1.81	2.82	121.9
WHE06-1836-060	60.0	0.60	6.8	1.07	1.15	1.20	1.25	1.30	0.76	1.11	1.69	2.19	3.42	152.4
WHE06-1836-072	72.0	0.72	7.5	1.07	1.15	1.20	1.25	1.30	0.88	1.30	1.98	2.57	4.03	182.9
WHE06-1836-080	80.0	0.80	8.0	1.07	1.15	1.20	1.25	1.30	0.96	1.43	2.17	2.82	4.43	203.2

MAXIMUM SPECIFICATIONS ARE PRODUCT MAXIMUM PLUS MEASURING SYSTEM UNCERTAINTY

NOTE: PRODUCT SPECIFICATIONS ARE VERIFIED AT 22°C, SEA LEVEL AND 20 TO 80% RELATIVE HUMIDITY.

PRODUCT SPECIFICATIONS APPLY AT 5 TO 99% (NON CONDENSING) RELATIVE HUMIDITY, CONSULT FACTORY FOR PRODUCT CHARACTERISTICS AT OTHER CONDITIONS.

6 GHz SMA Male to SMA Male Assembly

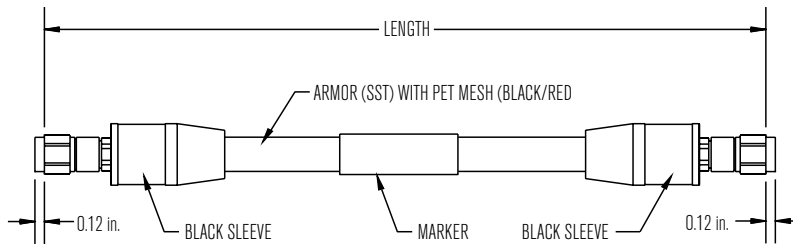

Electrical Specifications

IMPEDANCE, NOMINAL:	50 Ω			
CAPACITANCE NOMINAL:	29.3 pf/ft.			
VELOCITY OF PROPAGATION, NOMINAL:	69.5%			
RELATIVE SHIELDING:	> -100.0 dB MIN.			
INSULATION RESISTANCE:	1000 MΩ MIN.			
DIELECTRIC WITHSTANDING VOLTAGE:	1000 VRMS MIN.			
ELECTRICAL DELAY, NOMINAL:	N/A			
ELECTRICAL DELAY, NOMINAL:	N/A			
PULSE RF POWER:	1250 WATTS MAX.			
(INTO A 50 OHM SYSTEM, WITH DUTY CYCLE LESS THAN CW RATING)				
F (IN GHz) ----->	1	2	4	6
MAX. CW WATTS ----->	600	400	300	200
PHASE STABILITY DEG.	N/A	N/A	N/A	N/A
LOSS STABILITY dB --->	0.03	0.03	0.03	0.04

Materials and Finishes

Description	Material	Finish or Color
CABLE JACKET:	LP-389 FEP	BLUE
MARKER:	MIL-I-23053	WHITE
BOOTS:	MIL-I-23053	BLACK
CONTACTS:	ASTM B196 BeCu	MIL-G-45204 GOLD PLATED
INSULATORS:	ASTM D1457 PTFE	NONE
CONNECTOR BODIES:	ASTM A 582 303 STAINLESS STEEL	QQ-P-35 PASSIVATED
CONNECTOR NUTS:	ASTM A 582 303 STAINLESS STEEL	QQ-P-35 PASSIVATED
GASKETS:	ZZ-R-765 SILICONE RUBBER	RED
ARMOR:	STAINLESS STEEL	NONE
MESH:	PET	BLACK/RED
SOLVENTS:	NO OZONE DEPLETING MATERIALS ARE USED	

Mechanical Specifications

CABLE MAX. DIAMETER:	0.200 in.
PREFERRED BEND RADIUS:	3.90 in.
CONNECTOR RETENTION:	75 lbs. MIN.
TEMPERATURE RANGE:	-55 to +105°C
MATING TORQUE:	7-10 in. lbs.
CONNECTOR INTERFACES:	MIL-STD-348

Part Number	Length (Inches)	+ - Length	Weight (Ounces)	Maximum VSWR :1 at Frequency (in GHz)					Maximum Insertion Loss in dB/meter at Freq. (in GHz)					Length (CM)
				Up to 1	1 to 2	2 to 4	4 to 6	6 to 12	UP to 1	1 to 2	2 to 4	4 to 6	6 to 12	
WHE06-3636-018	18.0	0.18	3.3	1.07	1.15	1.20	1.25	1.30	0.23	0.39	0.60	0.78	1.09	45.7
WHE06-3636-020	20.0	0.20	3.4	1.07	1.15	1.20	1.25	1.30	0.25	0.42	0.65	0.84	1.18	50.8
WHE06-3636-024	24.0	0.24	3.7	1.07	1.15	1.20	1.25	1.30	0.29	0.48	0.74	0.95	1.35	61.0
WHE06-3636-030	30.0	0.30	4.0	1.07	1.15	1.20	1.25	1.30	0.36	0.57	0.87	1.13	1.62	76.2
WHE06-3636-036	36.0	0.36	4.3	1.07	1.15	1.20	1.25	1.30	0.42	0.66	1.01	1.30	1.88	91.4
WHE06-3636-040	40.0	0.40	4.6	1.07	1.15	1.20	1.25	1.30	0.46	0.72	1.09	1.41	2.05	101.6
WHE06-3636-048	48.0	0.48	5.0	1.07	1.15	1.20	1.25	1.30	0.54	0.84	1.27	1.64	2.41	121.9
WHE06-3636-060	60.0	0.60	5.7	1.07	1.15	1.20	1.25	1.30	0.66	1.02	1.54	1.98	2.93	152.4
WHE06-3636-072	72.0	0.72	6.4	1.07	1.15	1.20	1.25	1.30	0.78	1.20	1.81	2.32	3.46	182.9
WHE06-3636-080	80.0	0.80	6.9	1.07	1.15	1.20	1.25	1.30	0.86	1.32	1.99	2.55	3.81	203.2

MAXIMUM SPECIFICATIONS ARE PRODUCT MAXIMUM INCLUDING MEASURING SYSTEM UNCERTAINTY.

NOTE: PRODUCT SPECIFICATIONS ARE VERIFIED AT 22°C, SEA LEVEL AND 20 TO 80% RELATIVE HUMIDITY. SPECS FOR LENGTH OVER 240 INCHES ARE TYPICAL.

PRODUCT SPECIFICATIONS APPLY AT 5 TO 99% (NON CONDENSING) RELATIVE HUMIDITY, CONSULT FACTORY FOR PRODUCT CHARACTERISTICS AT OTHER CONDITIONS.

How to Order

1) Choose your product from the table below:

Armored WorkHorse® Cable Information						
Cable Code	Cable Type	Jacket Type	Center Conductor	Max. Frequency	Max. Insertion Loss (dB p/ft.)	Return Loss @ Max Freq.
06	564	FEP	Solid SPCW	6 GHz	0.85	-20.0 dB
18	544	FEP	Solid SPCW	18 GHz	0.73	-20.0 dB

2) Choose your connector codes from the table below:

Series	Type N	SMA
Plug	18	36

3) Choose your length in inches from the table below:

Length in Inches									
18	20	24	30	36	40	48	60	72	80

4) Build your assembly part number:

WHE XX-XX XX-XXX

Frequency in GHz. Choose from "06" or "18" or depending on the chosen cable

Connector A. Choose from the connector codes shown above

Connector B. Choose from the connector codes shown above

Length in Inches (i.e. 036 for 36" or 120 for 120")

**Note: the smaller digit code for Connector A and B will be listed first (e.g. WHE18-1836-036, not WHE18-3618-036)*



Other Products & Services

Assemblies

Avionics RF Assemblies

- » Leaky Feeder Assemblies
- » Low PIM Assemblies
- » Radio Altimeter Cable Assemblies
- » TCAS Cable Sets

Data Bus, Power & Video Assemblies

- » HDMI, DVI and Coax Digital Video Assemblies
- » Octax® High Speed Data Assemblies
- » FlightGear™ 5v Power Cable

Fiber Optic Assemblies

Harness Assemblies

High Density Coaxial Assemblies

- » HDRFI®
- » HDSI®

RF/Microwave Assemblies

- » AccuPhase® Low Loss Coaxial Assemblies
- » Conformable - Semi-Flex®
- » Semi-Rigid
- » WorkHorse® Test Assemblies

Connectors

Avionics RF Connectors

Backshells

- » Compact D-Sub Backshells
- » EN4165/BACC65 Series
- » Flexible Backshells
- » Multi-Exit Angle
- » Straight Exit Angle
- » Universal Spring Latches

Data Bus Connectors

- » Octax™ In-Line
- » Octax™ Ganged, EPX, 38999 & EN4165

EMI Protection & TVS

- » Circular Filtered
- » D-Sub and Micro-D Filter Connectors
- » EPX Filter Connectors
- » Rectangular Filtered
- » TVS - Transient Voltage Suppression Connectors

High Density Connectors

- » HDRFI®
- » HDSI®

RF/Microwave Connectors

- » Microwave Adapters
- » Phase Adjusters
- » Push-On Connectors
- » Swept/Radius Right Angle Connectors
- » Thread-On Connectors

Specialty Connectors

- » CB/CBX All Plastic Connectors
- » CBC Galley Connectors
- » CLP/CLPP Circular Connectors
- » CQ Connectors
- » Terminal & Grounding Blocks

Contacts

Coaxial Contacts

Crimp Contacts

Custom Designed Contacts

PC Tail Contacts

Solder Cup & Wire Wrap Contacts

Thermocouple Contacts

Services

Aircraft on Ground (AOG)

Build-to-Print Manufacturing

Certification Services

- » European Part Approval (EPA)
- » Parts Manufacturer Approval (PMA)
- » Supplemental Type Certificates (STCs)

Distribution

Engineering Services

- » Product Design
- » Qualification & Testing

Kitting Solutions

- » Aircraft Modification Kits
- » Fiber Optic Test & Inspection Kits

Custom Overbraiding Service

Structures

Antenna Mounts & Accessories

- » Antenna Doubler and Adapter Plates
- » Cable Feed Thru Assemblies
- » FlightGear™ Blind Mate Antenna Connector
- » Leaky Feeder Assemblies

ARINC LRC & Custom Enclosures

Custom Structural Components

- » Circuit Breaker Protection
- » Complex Machined Parts
- » Intercostal and Secondary Structures

Instrument/Control Panels

- » Backlit Switch Panels
- » FlightGear™ USB Power Port
- » FlightGear™ Smoke Detector Control Panels

Rack and Shelf Assemblies

- » Aluminum Equipment Racks
- » Aluminum Equipment Shelves
- » Composite Equipment Racks
- » Overhead Stowage Bin Racks and Structures

Trays

- » ABS1699 ARINC 600 Trays
- » ARINC 404A Trays
- » ARINC 600 Trays
- » Custom Trays and Mounts
- » Lightweight ARINC Trays

Tray Accessories

- » Advanced Thumbscrew Hold-Downs
- » Insertion-Extraction Hold-Downs
- » Military Style Hold-Downs
- » Negative Pressure Air Filtration Systems
- » Positive Pressure Air Filtration Systems
- » Sensors
- » Stand-Offs

Systems

Automatic Dependant Surveillance Broadcast (ADS-B)

EFB Electronic Flight Bag Systems

- » EZMount® Tablet Cradle
- » EZMount® EFB Mounting solutions

- » FlightGear™ USB Power Port

- » FlightGear™ 5v Power Cable

Global Positioning System/Multi-Mode Receiver (GPS/MMR)

In-Flight Entertainment & Connectivity SATCOM

Traffic Alert & Collision Avoidance System (TCAS)

Wire & Cable

Cable Assembly & Repair

- » Coaxial Cable Stripper
- » Crimp Splices
- » Heatless Crimp Splices
- » Tie Cords & Lacing Tapes

Commercial UL/CSA Wire

Composite Aerospace Wire

- » BMS 13-60
- » Seamless™ AS22759/80-/92
- » Seamless-T™ AS22759/180-/192
- » Tufflite® Enhanced Normal Weight - ST
- » Tufflite® European Metric - TLR

Fiber Optic Cable

- » LITEflight® EP
- » LITEflight® HD
- » Fiber Optic Test & Inspection Kits

Harsh Environment, Engine, Firezone & SWAMP

- » BMS 13-55
- » BMS 13-58
- » EFGLAS Equipment Wire & Cable
- » ESW Firezone Specifications
- » MIL-W-25038 Wire

High Performance Coax

- » AccuPhase® Low Loss Coaxial Cable
- » Avionics RF Cable
- » BMS 13-65
- » MaxForm® Formable Coaxial Cable
- » MIL-C-17 Coaxial Cable
- » TMaxx™ Low Loss Coaxial Cable

High Speed Digital & Data Cable

- » Boeing Approved Data Cables
- » General Aviation Data Cables
- » Gigabit Ethernet Series
- » Maxflite® Cables
- » Netflight® Cables

Industrial Wire & Cable

- » Anode Cables for Cathodic Protection
- » PEEK Equipment Wire & Cable
- » Polyimide Equipment Wire & Cable
- » Thermocouple Cables
- » Zyrad™ and Trakrad™ Wire

Mil-Spec Hookup Wire

- » AS22759 Wire
- » MIL-C-17 Coaxial Cable
- » MIL-DTL-27500 Cable
- » MIL-W-16878 Wire (NEMA HP3, HP4)
- » MIL-W-25038 Wire
- » MIL-W-81381 Wire
- » MIL-W-81822 Wire

Specialty Cables

- » Coil Cords
- » Heating Cables
- » Low-Noise Cable

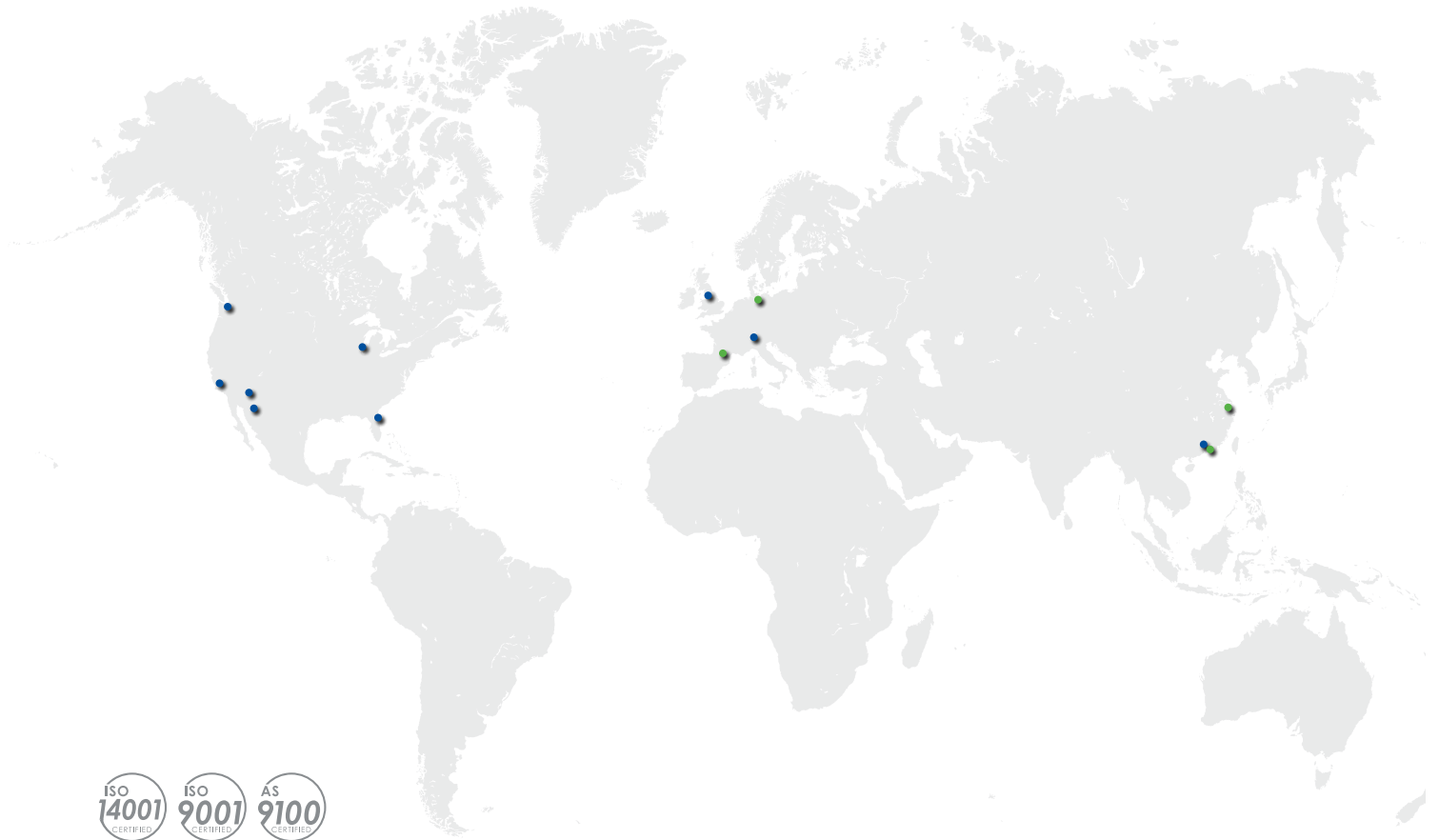

All of our facilities are
ISO9001 & AS9100 Registered

● Manufacturing & Sales ● Sales

ST. AUGUSTINE, FL
Corporate Headquarters
Manufacturing & Sales
T 800.458.9960 / F 904.824.6706

EL SEGUNDO, CA
Manufacturing & Sales
T 310.536.0444 / F 310.536.9322

FRANKLIN, WI
Manufacturing & Sales
T 800.327.9473 / F 414.421.5301

LUGANO, SWITZERLAND
Manufacturing
T 41.91.611.51.61 / F 41.91.611.51.67

TEMPE, AZ
Manufacturing & Sales
T 480.730.5700 / F 480.730.5800

RIVERSIDE, CA
Manufacturing
T 951.788.0252 / F 951.788.6226

DONGGUAN, CHINA
Manufacturing & Sales
T +86.769.8102.6363 / F +86.769.8345.4972

SHENZHEN, CHINA
Manufacturing
T +86.755.298.3000

CERRITOS, CA
Manufacturing & Sales
T 866.282.4708 / F 562.494.0955

KENT, WA
Manufacturing & Sales
T 800.227.5953 / F 425.251.8826

NOGALES, MEXICO
Manufacturing & Sales
T +52.631.3146105

LITTLEBOROUGH, UNITED KINGDOM
Manufacturing & Sales
T +44.1706.374015 / F +44.1706.370576

