

***** THIS DRAWING AND ITS CONTENTS ARE THE SOLE PROPERTY OF PRECISION CONNECTOR INC. AND ARE SUBJECT TO CHANGE WITHOUT NOTICE UNLESS OTHERWISE SPECIFIED *****

REV.	DESCRIPTION	DATE	BY	APPVD
A	INITIAL RELEASE	08/30/11	RDE	MJK

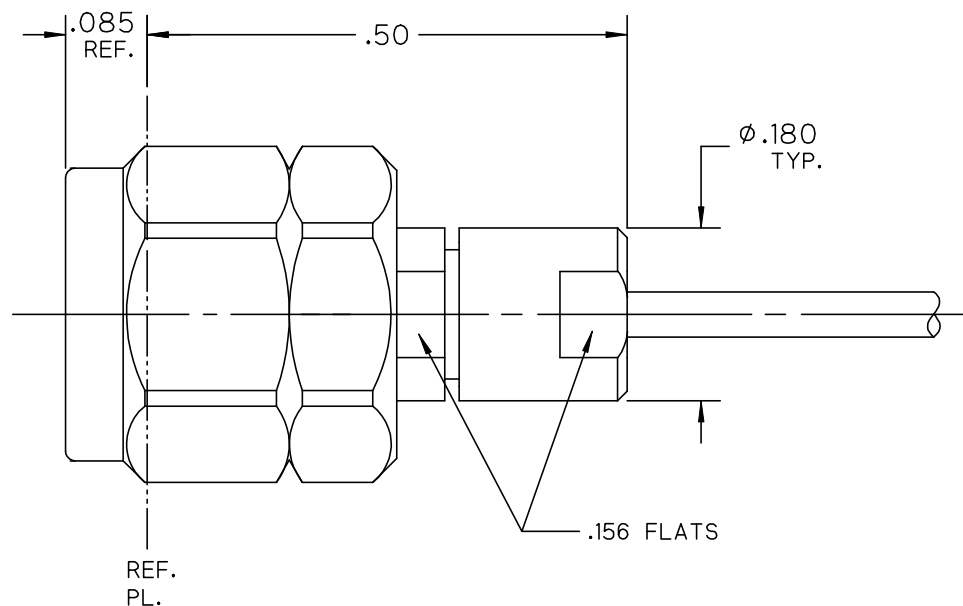
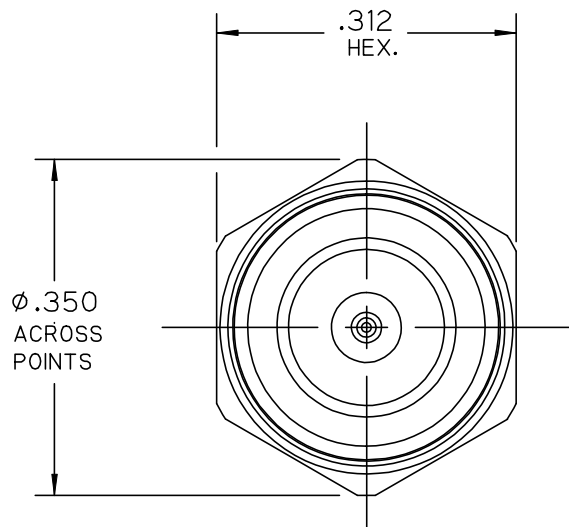

NOTE: DISTANCE FROM END OF CABLE CENTER COND. TO REF. PL. IS $.330$

NOTES :

1.0 MATERIALS:

- 1.1 BODY, BUSHING, COUPLING & CLAMP NUT: STEEL, CORROSION RESISTANT PER ASTM-A582, UNS NO. S30300.
- 1.2 CENTER COND.: BERYLLIUM COPPER PER ASTM-B196, UNS C17300.
- 1.3 SOLDER FERRULE: BRASS PER ASTM-B16, UNS C36000.
- 1.4 LOCK RING: BERYLLIUM COPPER PER ASTM-B197, UNS C17200.
- 1.5 GASKET: SILICONE RUBBER PER A-A-59588.
- 1.6 DIELECTRIC BEAD: POLYETHERIMIDE THERMOPLASTIC (ULTEM 1000) PER ASTM-D5205.

2.0 FINISHES:

- 2.1 CENTER COND. & SOLDER FERRULE: GOLD PLATE PER ASTM-B488, 50 MICROINCHES MIN. THK. OVER ELECTROLYTIC NICKEL PLATE PER ASTM-B689 50 MICROINCHES MIN. THK.
 - 2.2 BODY, BUSHING, COUPLING & CLAMP NUT: PASSIVATE PER SAE-AMS-2700.
 - 2.3 GASKET, LOCK RING & DIELECTRIC: NONE.
- 3.0 INTERFACE PER PCI-1.85mm-PIN.



TOLERANCES UNLESS OTHERWISE SPECIFIED	DRAWN BY: RDE	DESC.: 1.85mm PLUG, SOLDER CLAMP FOR .047 SEMI-RIGID CABLE			
.XX ± .02	DATE: 08/30/11	SCALE	SHEET NO.	DRAWING NUMBER	REV
.XXX ± .005	CAGE CODE	5:1	1 OF 1	3634-0L	A
.XXXX ± .0005	4MJR5				
ANGLES ± 2°					