

1

2

3

4

ZONE	REV	DESCRIPTION OF REVISION	ECN NO.	BY	DATE	APPROVED
	A	INITIAL ISSUE	LAB	M&M	06/21/04	A.T.

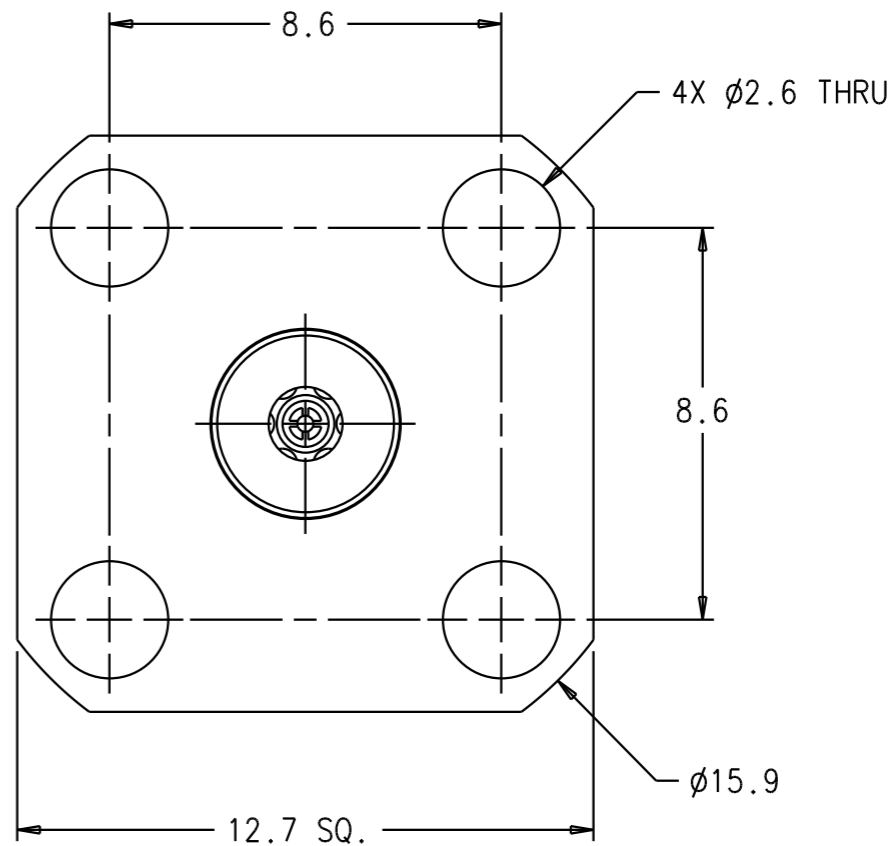
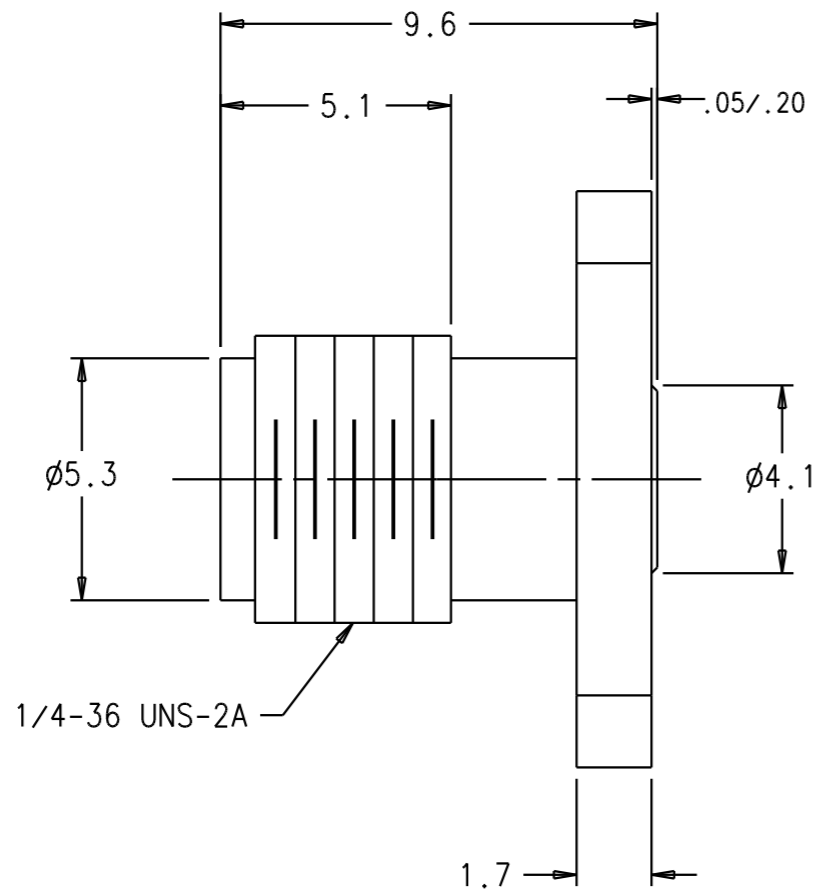

NOTES:

1. ELECTRICAL :
 - 1.1 FREQUENCY: DC TO 40GHz
 - 1.2 VSWR: 1.433
2. MECHANICAL :
 - 2.1 FRONT-SIDE PIN DEPTH: 0.000 TO 0.13mm
3. OPERATING TEMPERATURE: -55°C TO +125°C
4. MATERIAL :
 - 4.1 OUTER CONDUCTOR: PASSIVATED STAINLESS STEEL.
 - 4.2 BEAD HOLDER: PASSIVATED STAINLESS STEEL.
 - 4.3 CENTER CONDUCTOR: HEAT TREATED BERYLLIUM COPPER, GOLD PLATED OVER NICKEL.
 - 4.4 DIELECTRIC: POLYPHENYLENE OXIDE.

DIMENSIONS ARE FOR REFERENCE ONLY

UNLESS OTHERWISE SPECIFIED, ALL DIMENSIONS ARE IN MILLIMETERS (mm)	DRAWN	M. MEZA	DATE	06/21/04	MATERIAL: SEE SEPARATED PRODUCT STRUCTURES	
	CHECKED	A. THOMAS	DATE	06/21/04	490 JARVIS DRIVE MORGAN HILL, CA. 95037	
	APPROVED	A. THOMAS	DATE	06/21/04		
SEE PRODUCT STRUCTURE _____	TOLERANCES: UNLESS OTHERWISE SPECIFIED		TITLE			
ALL INFORMATION SHOWN ON THIS SPECIFICATION IS PROPRIETARY INFORMATION OF ANRITSU COMPANY	1 PLACES	ANGLES	OUTLINE, K104F CONNECTOR			
	2 PLACES	SURFACE FINISH	FSCM NO.		DRAWING NO.	REV
	3 PLACES		20944	63326	A	
DO NOT SCALE DRAWING	FINISH	----	SCALE	UNDER ECN CONTROL	06/04 BY A.T. DATE M.E	SHEET 1 OF 1

1

2

3

4