

NOTE: Information herein is believed by Southwest Microwave, Inc. to be accurate. However, Southwest Microwave assumes no responsibility for any omissions or errors or inaccuracies for its use or for any infringements of patents or other rights of third parties that may result from its use. Data is intended for informational purpose only and does not constitute a contract of sale or any express or implied warranty, including any warranty of merchant ability or fitness for a particular purpose.

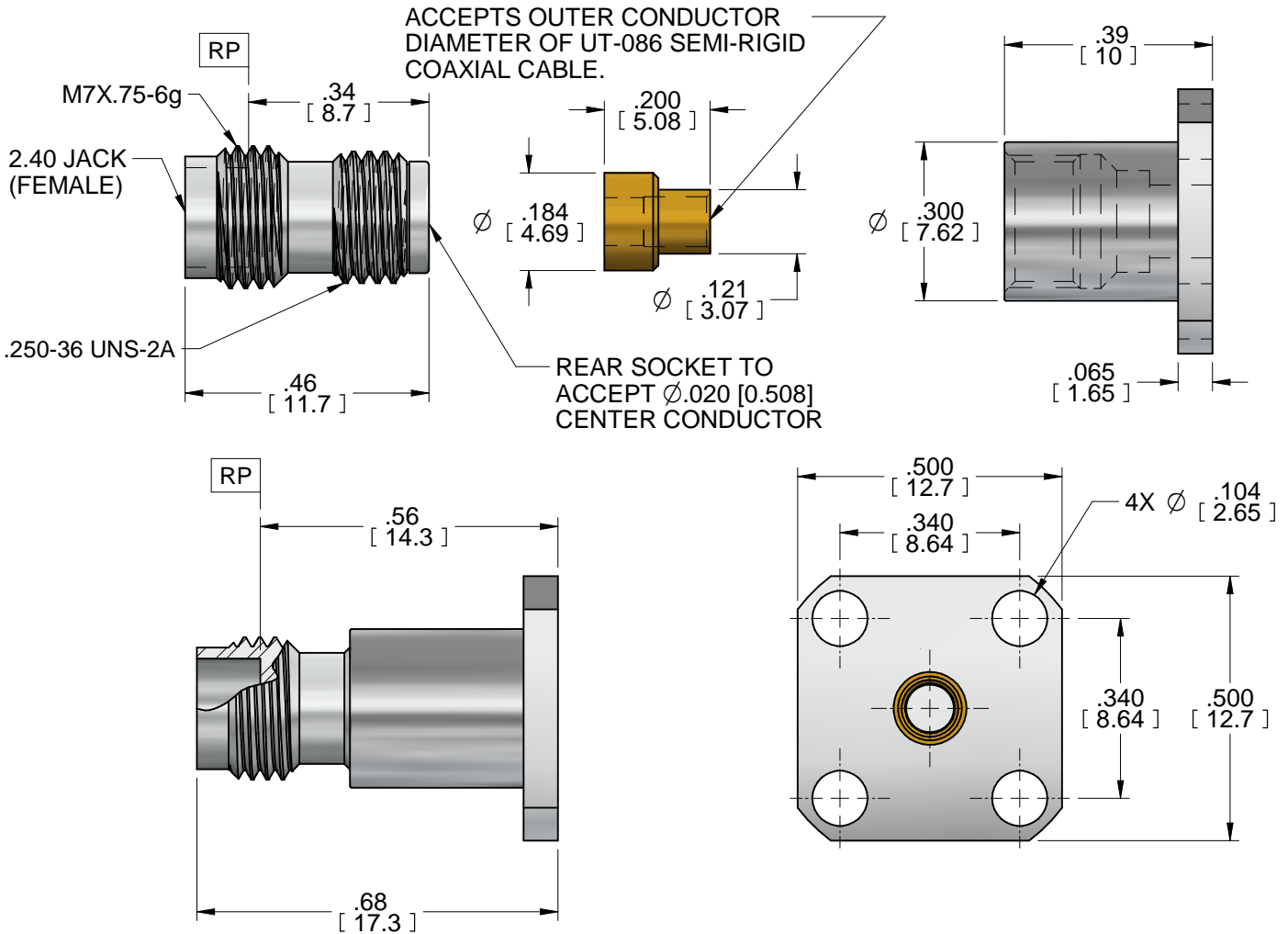

CABLE ASSY. INSTR.:	91S59287
CONTACT GAGING SPEC.:	91P55468
SPECIFICATION:	91P56087
INTERFACE:	91P53661
SPECIFICATION GROUP	DRAWING NO.

HOUSING & FLG CBL NUT:	STEEL, CRES ALLOY UNS-30300 PER ASTM A582 PASSIVATE PER ASTM A967
CONTACT :	BeCu UNS-C17300 PER ASTM B196/197 GOLD PLATE PER MIL-DTL-45204
CABLE ADP:	C360 BRASS ALLOY UNS-C36000 PER ASTM B16 GOLD PLATE PER MIL-DTL-45204
DIELECTRIC:	KEL-F PER ASTM D1430
DIELECTRIC:	ULTEM 1000 PER ASTM D5205
ITEM	MATERIAL & FINISH

1. ALL DIMENSIONS ARE IN INCHES. ALL ANGLES ARE IN DEGREES. DIMENSIONS SHOWN IN BRACKETS [XXX] ARE IN MILLIMETERS.

NOTES: UNLESS OTHERWISE SPECIFIED.

REV A	RELEASED	DATE: 3/17/14	APRVD. PLC	DATE: 3/17/14	TITLE 2.40 JACK (F) 4 HOLE REAR MOUNT FLANGE CABLE CONNECTOR ACCEPTS .086 SEMI-RIGID CABLE			
 <p>Southwest Microwave, Inc. 9055 South McKemy Street Tempe, Arizona 85284-2946 Telephone (480) 783-0201 Fax (480) 783-0360</p>					DRN BY: EJO	DATE: 9/7/11	MODEL NO. 1402-06SF	REV. A
					SCALE: 3:1		DWG. NO. 79P60664	
					SHEET: 1 OF 1			