

***** THIS DRAWING AND ITS CONTENTS ARE THE SOLE PROPERTY OF PRECISION CONNECTOR INC. AND ARE SUBJECT TO CHANGE WITHOUT NOTICE UNLESS OTHERWISE SPECIFIED *****

| REV. | DESCRIPTION | DATE | BY | APPVD |
|------|-----------------|----------|-----|-------|
| A | INITIAL RELEASE | 07/24/07 | MJK | MJK |
| | | | | |
| | | | | |

NOTES :

1.0 MATERIALS:

- 1.1 BODY & CENTER CONTACT: BERYLLIUM COPPER PER ASTM-B196. UNS NO. C17300.
- 1.2 COUPLING NUT: STEEL. CORROSION RESISTANT PER ASTM-A582. UNS NO. S30300.
- 1.3 LOCK RING: BERYLLIUM COPPER PER ASTM-B197. UNS NO. C17200.
- 1.4 GASKET: SILICONE RUBBER PER A-A-59588.
- 1.5 DIELECTRIC BEAD: POLYPHENYLENE OXIDE (NORYL) PER ASTM-D4349.

2.0 FINISHES:

- 2.1 BODY & CENTER CONTACT: GOLD PLATE PER ASTM-B488. 50 MICROINCHES MIN. THK. OVER ELECTROLYTIC NICKEL PLATE PER ASTM-B689 50 MICROINCHES MIN. THK.
- 2.2 COUPLING NUT: PASSIVATE PER SAE-AMS-2700.
- 2.3 GASKET, LOCK RING AND DIELECTRIC BEAD: NONE.

3.0 INTERFACE : 2.4mm PIN PER IEEE-STD-287, FIGURE H.3 (GPC)

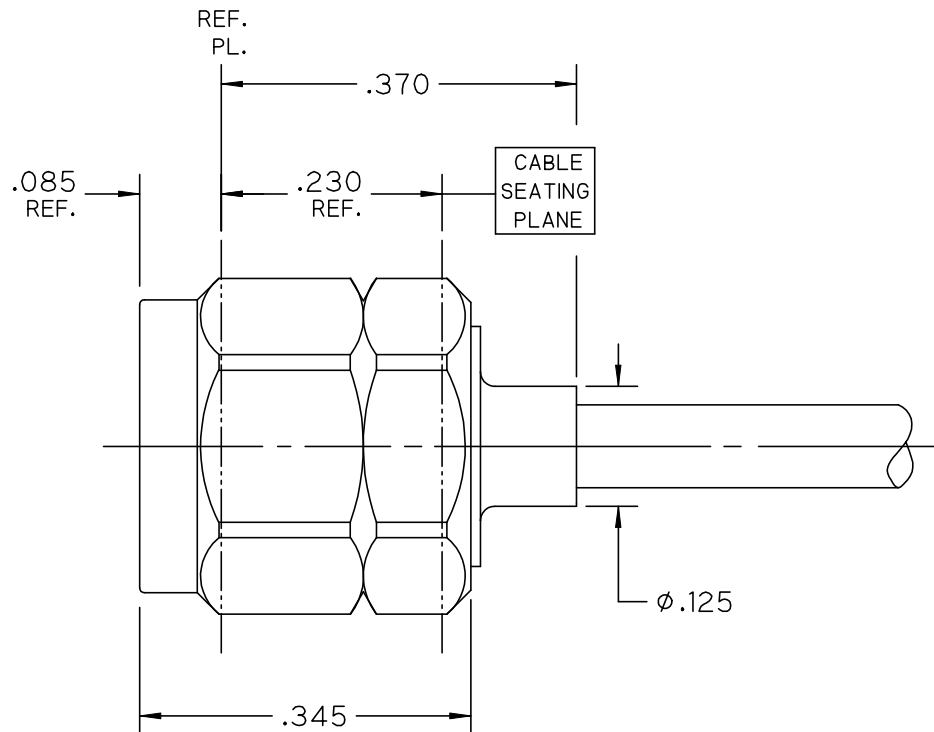

NOTE: DISTANCE FROM END OF CABLE CENTER COND. TO REF. PL. IS .155

REF. OLD P/N 1-000-4085-0



| | | | | | |
|---------------------------------------|---------------------------|---|-----------|----------------|-----|
| TOLERANCES UNLESS OTHERWISE SPECIFIED | DRAWN BY: MJK | PART DESCRIPTION: | | | |
| | DATE: 07/24/07 | 2.4mm PLUG, DIRECT SOLDER TO RG-405 CABLE | | | |
| .XX ± .02 | CAGE CODE 4MJR5 | SCALE | SHEET NO. | DRAWING NUMBER | REV |
| .XXX ± .005 | | 6:1 | 1 OF 1 | 3203-0L | A |
| .XXXX ± .0005 | | | | | |
| ANGLES ± 2° | | | | | |