

***** THIS DRAWING AND ITS CONTENTS ARE THE SOLE PROPERTY OF PRECISION CONNECTOR INC. AND ARE SUBJECT TO CHANGE WITHOUT NOTICE UNLESS OTHERWISE SPECIFIED *****

REV.	DESCRIPTION	DATE	BY	APPVD
A	INITIAL RELEASE	02/13/12	MJK	MJK

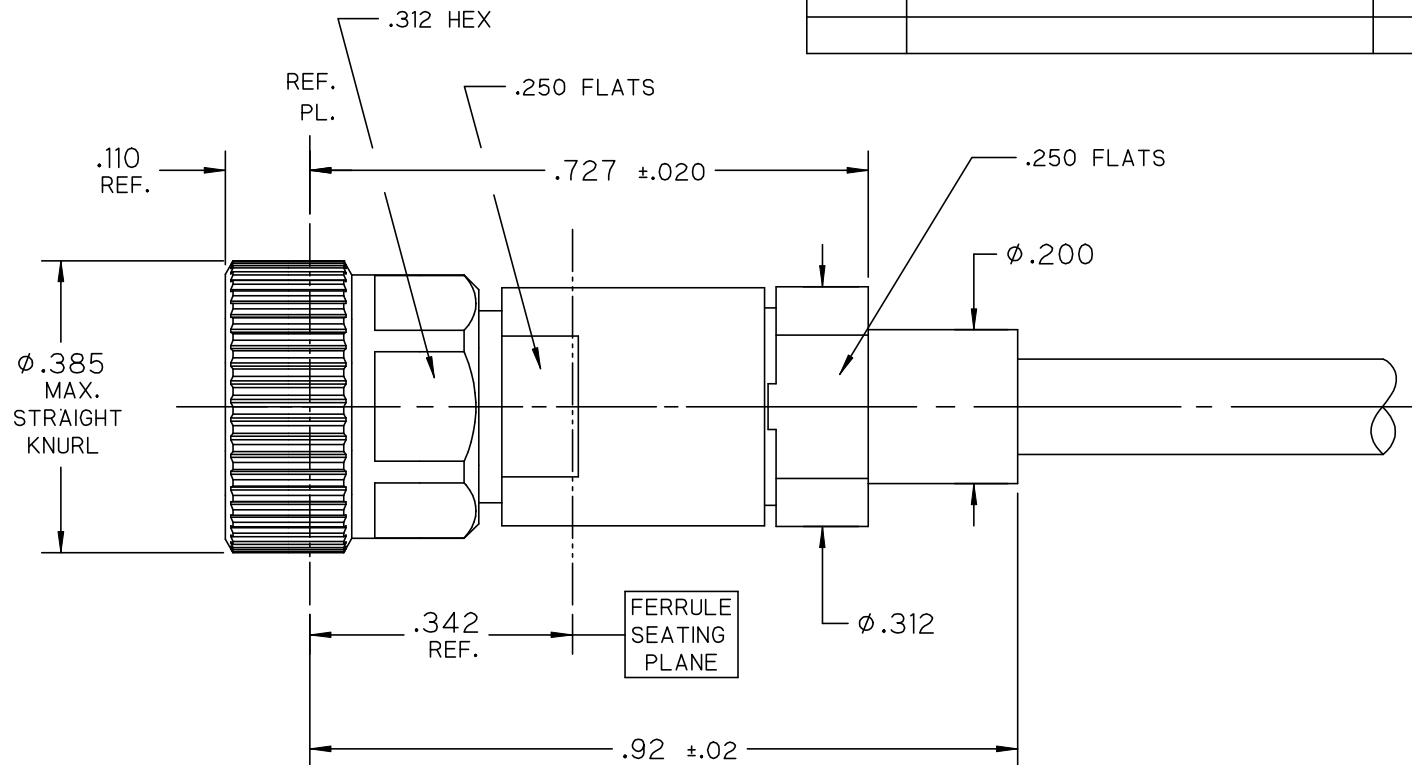

NOTES :

1.0 MATERIALS:

- 1.1 BODY, COUPLING & CLAMP NUTS: STEEL, CORROSION RESISTANT PER ASTM-A582, UNS NO. S30300.
- 1.2 CENTER COND.: BERYLLIUM COPPER PER ASTM-B196, UNS C17300.
- 1.3 SOLDER FERRULE: BRASS PER ASTM-B16, UNS C36000.
- 1.4 LOCK RING: BERYLLIUM COPPER PER ASTM-B197, UNS C17200.
- 1.5 GASKET & O-RING: SILICONE RUBBER PER A-A-59588.
- 1.6 DIELECTRIC BEAD: POLYPHENYLENE OXIDE (NORYL) PER ASTM-D4349.
- 1.7 CABLE STOP: POLYETHERIMIDE THERMOPLASTIC (ULTEM 1000) PER ASTM-D5205.

2.0 FINISHES:

- 2.1 CENTER CONTACT & SOLDER FERRULE: GOLD PLATE PER ASTM-B488, 50 MICROINCHES MIN. THK. OVER ELECTROLYTIC NICKEL PLATE PER ASTM-B689 50 MICROINCHES MIN. THK.
 - 2.2 BODY, COUPLING & CLAMP NUTS: PASSIVATE PER SAE-AMS-2700.
 - 2.3 GASKET, O-RING, LOCK RING & DIELECTRICS: NONE.
- 3.0 INTERFACE PER PCI-2.92mm-PIN.



TOLERANCES UNLESS OTHERWISE SPECIFIED	DRAWN BY: MJK	DESC.: 2.92mm PLUG, SOLDER CLAMP FOR SEMIFLEX HP120 CABLE, KNURL/HEX NUT			
	DATE: 02/13/12	SCALE	SHEET NO.	DRAWING NUMBER	REV
.XX ± .02	CAGE CODE	5:1	1 OF 1	3321-OL	A
.XXX ± .005	4MJR5				
.XXXX ± .0005					
ANGLES ± 2°					