

CATALOG NUMBER	"A" INTERFACE
A003-N33-02	FULL DETENT
A003-N34-02	LIMITED DETENT
A003-N35-02	SMOOTH BORE

MATERIAL AND FINISH

SHROUD AND BUSHING: CRES 303; PASSIVATED
 CENTER CONTACT: BeCu; GOLD PLATE 50-100 MICRONS OVER NICKEL PLATE 50 MICRONS MIN.
 DIELECTRIC: VIRGIN PTFE (TEFLON)

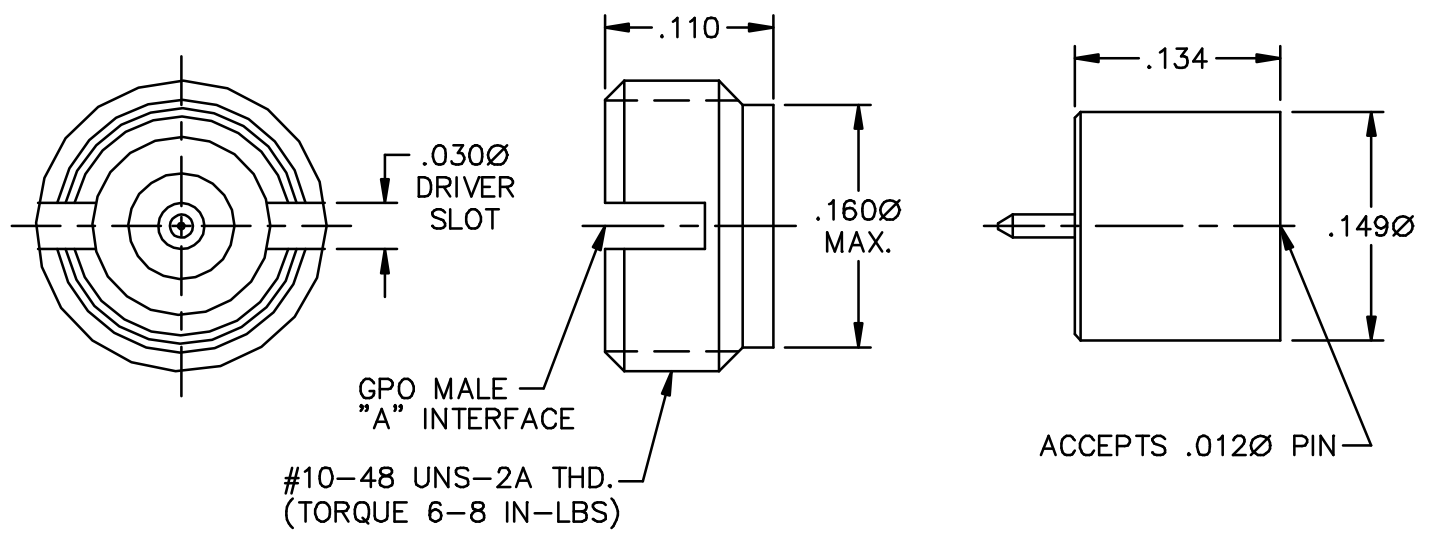
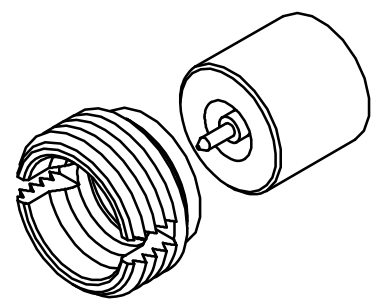

RECOMMENDED TOOLS:

- A097-A99-01: -THREAD-IN DRIVER, FULL DETENT
- A097-A99-02: -THREAD-IN DRIVER, LIMITED DETENT
- A097-A99-03: -THREAD-IN DRIVER, SMOOTH BORE
- L091-A99-01: -#10-48 STARTING TAP
- L091-A99-02: -#10-48 BOTTOM TAP

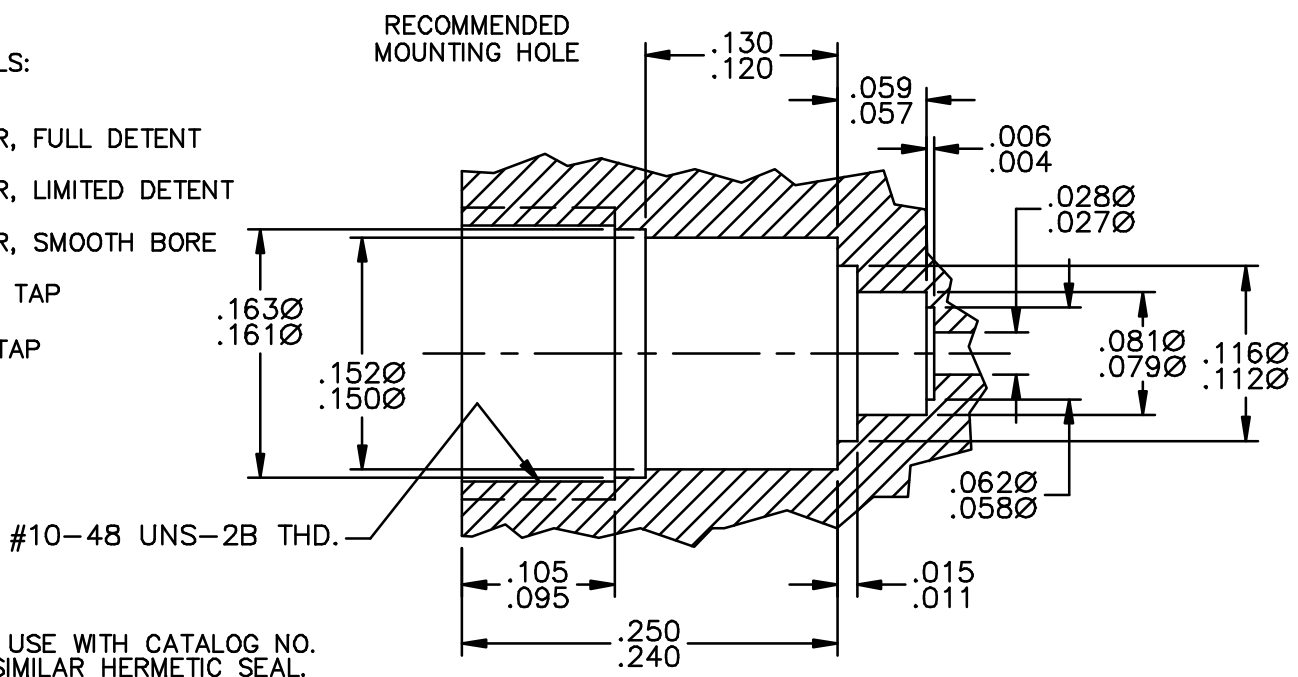

RECOMMENDED FOR USE WITH CATALOG NO. Y007-L42-01 OR SIMILAR HERMETIC SEAL.

This drawing and any data contained herein is the property of Corning Gilbert Inc., and constitutes and contains proprietary and confidential information. Neither receipt nor possession of this drawing confers or transfers any right to duplicate, use or disclose any information contained herein except as expressly authorized by Corning Gilbert Inc.

GPO MALE THREAD-IN SHROUD ACCEPTS .012 PIN (TAB DETENT)	IDENT CODE: 82316	Corning Gilbert Inc.
	REVISION: A	
SOURCE FILE: SK-2004	DWG. NO.: A003-N3X-02	ASSY. PROC.: -