

BMA8305-0085

BMA Jack Solder For Bulkhead 50Ω

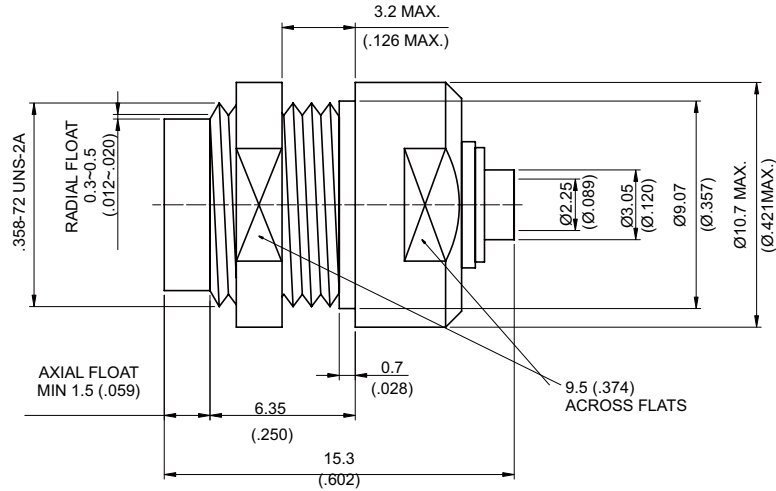

MOUNTING HOLE

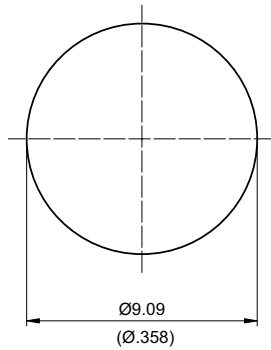

Parts	Material	Plating (Micro-inch)
Spring Washer	Beryllium Copper	Gold 5 over Nickel 50 over Copper 50
Spring Ring	Beryllium Copper	Gold 5 over Nickel 50 over Copper 50
Spring	Stainless Steel	Passivated
Nut	Stainless Steel	Passivated
E-ring	Stainless Steel	Passivated
Contact Pin	Beryllium Copper	Gold 20 over Nickel 50 over Copper 50
Insulator	Teflon	
Solder Body	Stainless Steel	Gold 5 over Nickel 50 over Copper 50
Body	Stainless Steel	Passivated

Weight: 5.11 g
Suitable Cables: Semi-rigid.085

This part number complies with RoHS.

Notice: JYEBAO reserves the right to make modifications deemed appropriate.

CABLE ASSEMBLY INSTRUCTION

BMA8305-0085

JYE BAO CO., LTD.

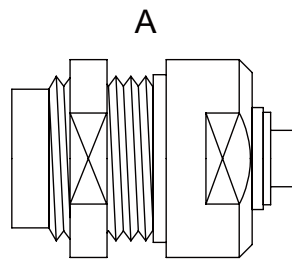

BODY AND NUT

DIAGRAM	ASSEMBLY INSTRUCTION
	<p>Step 1: STRIP AS SHOWN .</p>
<p style="text-align: center;">SHARPEN</p>	<p>Step 2: SHARPEN CENTER CONDUCTOR TIP.</p>
	<p>Step 3: SLIDE CABLE INTO CONNECTOR BODY "A".</p>
	<p>Step 4: INSERT PREPARED CABLE INTO SOLDERING FIXTURE " ST-008 ". USE INSERT TOOL " ST-009 " AND LOCATOR TOOL " ST-011 " TO FIX THE CONNECTOR. SOLDER IN " Y ".</p>

This part number complies with RoHS.

Notice: JYEBAO reserves the right to make modifications deemed appropriate.