

ENVELOPE / ASSEMBLY DRAWING

000360

SPECIFICATION CONTROL DRAWING

THIS DRAWING CONTAINS INFORMATION PROPRIETARY TO RF INDUSTRIES, LTD. ANY UNAUTHORIZED USE OF THIS DRAWING IS EXPRESSLY PROHIBITED. ANY VIOLATION IS PUNISHABLE UNDER U.S. COPYRIGHT LAWS.

REV	DESCRIPTION	DWN	DATE	APPROVED
A	ENGINEERING RELEASE	CZS	8/4/98	R. RICE
B	CONNECTOR NOW WILL ACCEPT MAX PANEL THICKNESS OF .200	CZS	9/3/98	R. RICE
C	REMOVED 83284 FROM APPROVED CABLE LIST	JDMc	2/1/06	R. RICE

ALL DIMENSIONS ARE REFERENCE ONLY

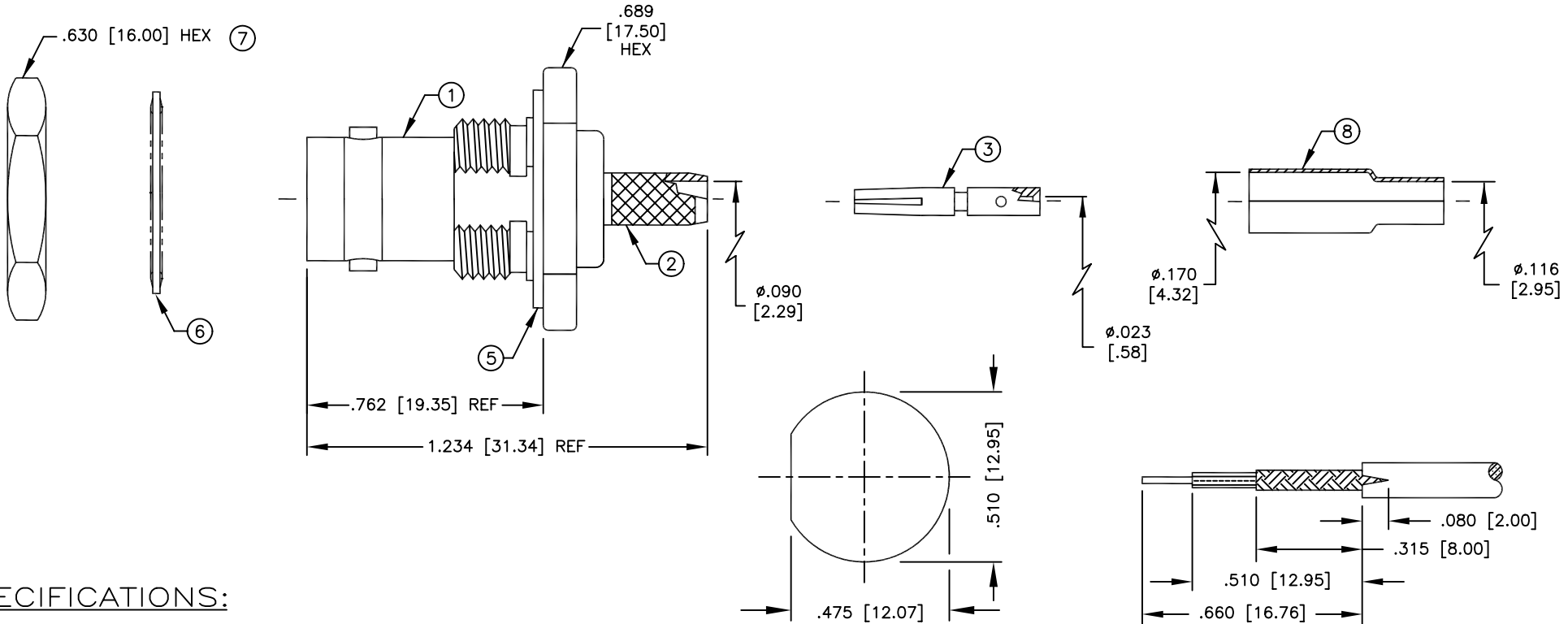

SPECIFICATIONS:

IMPEDANCE: 50 Ohms
 WORKING VOLTAGE: 500 VRMS @ SEA LEVEL
 FREQUENCY RANGE: 0-4 GHz
 INSERTION LOSS: \leq -.2 dB @ 3 GHz
 VSWR MAX: 1.4:1 @ 3 GHz
 FOR RG-174, 188, 188A, 316/U, ALPHA 9174, 9316,
 BELDEN 8216, 83269, 84316 & TIMES LMR-100 CABLE
 INTERFACE PER MIL-STD-348A, SECTION 301.2

PANEL MOUNTING CONFIG
 MAXIMUM PANEL THICKNESS: .200 [5.08]

SUGGESTED STRIPPING INSTRUCTIONS
 SUGGESTED CRIMP DIE: .068, .178 & .130

ITEM	DESCRIPTION	QTY	MATERIAL	FINISH
8	FERRULE	1	BRASS	NICKEL
7	HEX NUT	1	BRASS	NICKEL
6	LOCK WASHER	1	BRASS	NICKEL
5	GASKET	1	S.I. RUBBER	RED
4	DIELECTRIC	1	TEFLON	NONE
3	CONTACT	1	BRASS	GOLD
2	PRESS-FIT FER STUD	1	BRASS	NICKEL
1	BODY	1	BRASS	NICKEL

DIMENSIONS ARE IN INCHES AND [MILLIMETERS]

UNLESS OTHERWISE NOTED TOLERANCES ARE:

DECIMALS DIAMETER
 .xxx±.003 [.08] .xxx±.001 [.03]
 .xx±.005 [.13] .xx±.003 [.08]

ANGLES: ±1°

DRAWN C. ZUNIGA 2/1/06

CHECKED

ORJ DRAWN C. ZUNIGA 8/4/98

APPROVALS DATE



7610 MIRAMAR RD
 SAN DIEGO, CA 92126
 (619)549-6340
 (619)549-6345 FAX

RFB-1117-BT

BNC FEMALE CRIMP BULKHEAD, REAR MOUNT

SIZE	CABLE GROUP	DWG NO.	REV
A	B	RFB-1117-BT	C

SCALE: 2:1 CAD FILE 13ARC B SHEET 1 OF 1