

THIS DRAWING CONTAINS INFORMATION PROPRIETARY TO RF INDUSTRIES.  
 ANY UNAUTHORIZED USE OF THIS DRAWING IS EXPRESSLY PROHIBITED  
 WITHOUT WRITTEN PERMISSION FROM RF INDUSTRIES.  
 ANY VIOLATION IS PUNISHABLE UNDER U.S. COPYRIGHT LAWS.

ALL DIMENSIONS ARE REFERENCE ONLY

PART NO.		<b>RFB-1106-5</b>		
REV	DESCRIPTION	DWN	DATE	APPROVED
A	ENGINEERING RELEASE	CZS	8/12/99	R. RICE
B	CHANGE FORMAT & DWG # 9226	GGG	02/4/02	JDMc

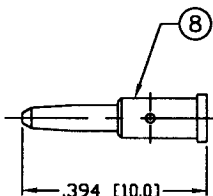
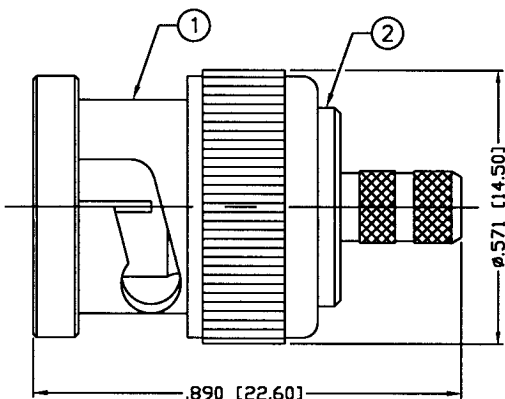

RECOMMENDED CRIMP DIE: .068"

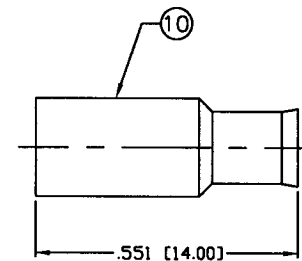
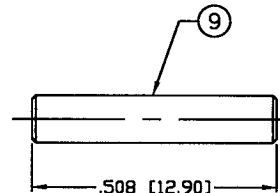

RECOMMENDED CRIMP  
DIE: .130" & .178"

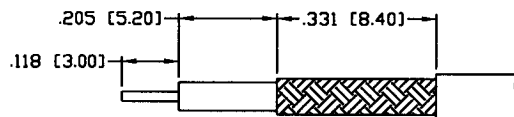

RECOMMENDED  
STRIPPING DIMENSIONS

**SPECIFICATIONS:**

IMPEDANCE: 50 Ohms  
 FREQUENCY RANGE: 0-4 GHz  
 VSWR: 1.3 Max.  
 WORKING VOLTAGE: 500 V rms @ sea level  
 TEMPERATURE RANGE: -65°C TO 85°C  
 INSULATION RESISTANCE: 5k M Ohms min.  
 FOR RG-174, 188, 188A, 316/U, ALPHA 9174, 9316,  
 BELDEN 8216, 83269, 83284, 84316 & TIMES LMR-100A CABLE

1	SHELL	1	BRASS	NICKEL, 100μ"
2	BODY	1	BRASS	NICKEL, 100μ"
3	INSULATOR	1	PTFE	---
4	GASKET	1	RUBBER	---
5	RETAINING RING	1	BRASS	NICKEL, 100μ"
6	SPRING	1	SK5	NICKEL, 200μ"
7	WASHER	1	BRASS	NICKEL, 100μ"
8	PIN	1	BRASS	GOLD, 3μ"
9	INSERT	1	DELTRIN	---
10	FERRULE	1	BRASS	NICKEL, 100μ"
11				
12				
13				
14				
#	DESCRIPTION	QTY	MATRL	FINISH

008974	
DRAWN	G. GALLEGOS
CHECKED	<i>JDM</i> 2-15-02
ORJ DRAWN	C. ZUNIGA
DATE	8/12/99

UNLESS OTHERWISE SPECIFIED:

- REMOVE ALL BURRS
- BREAK ALL CORNERS & EDGES .005 R. MAX.
- CHAMFER 1ST & LAST THREADS 45°
- SURFACE ROUGHNESS 63 FINISH MIL-STD-10
- DIAMETERS ON COMMON CENTERS TO BE CONCENTRIC WITHIN .002 T.I.R.
- ALL DIMENSIONS ARE AFTER PLATING.

DIMENSIONS ARE IN INCHES AND [MILLIMETERS]  
 UNLESS OTHERWISE NOTED TOLERANCES ARE:

DECIMALS	DIAMETER
.xxx±.003 [.08]	.xxx±.001 [.03]
.xx±.005 [.13]	.xx±.003 [.08]

RF

7610 MIRAMAR RD  
 SAN DIEGO, CA 92126  
 (858) 549-6340  
 (858) 549-6345 FAX

DIVISION OF RF INDUSTRIES, LTD.

## BNC PLUG CRIMP

SIZE	CABLE GROUP	DWG NO.	REV
A	B	RFB-1106-5	B

SCALE: NTS      CAD FILE OUTLINE      SHEET 1 OF 1