

4

3

2

1

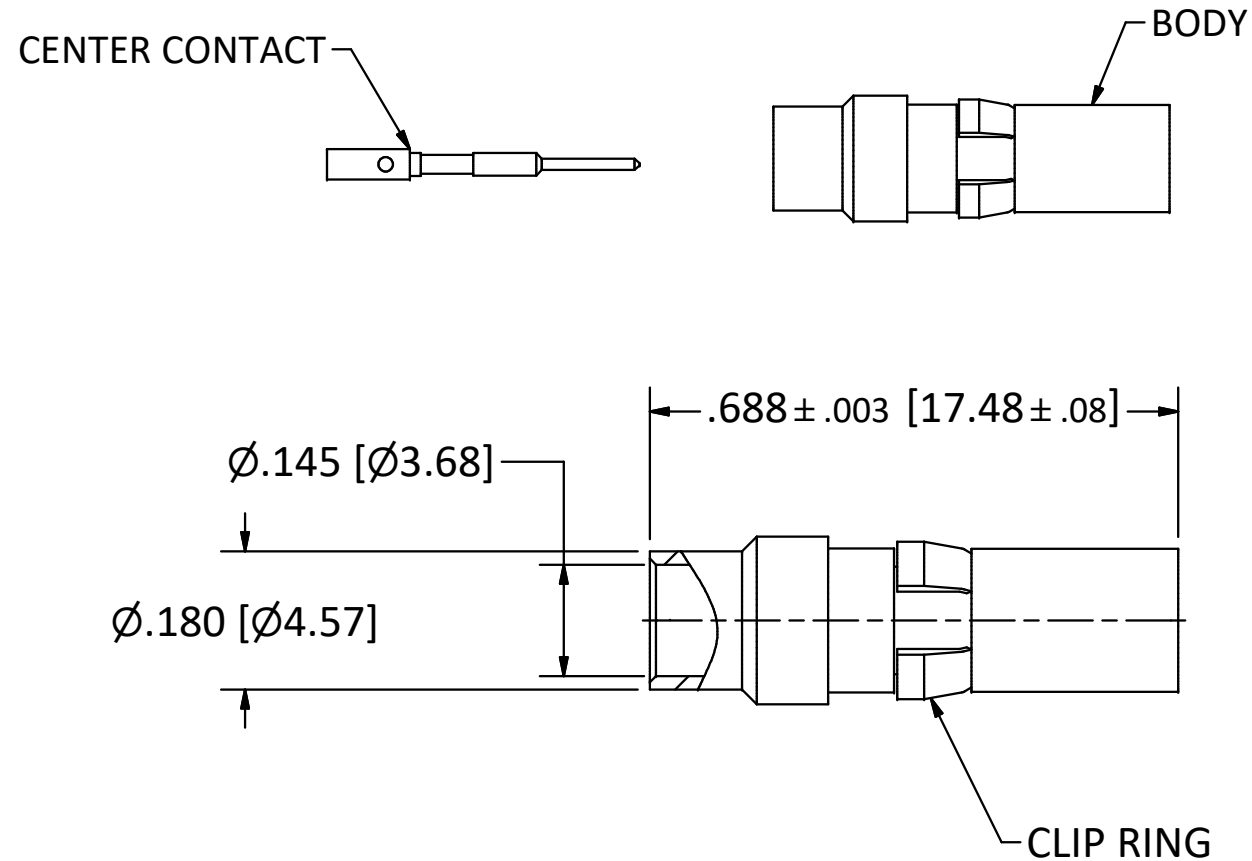

NOTES:

- 1. SPECIFICATIONS PER IDS-28.
 - 2. ACCOMMODATES RG-402 (.141 SEMI-RIGID) OR EQUIVALENT FLEXIBLE CABLE.
 - 3. CENTER CONTACT SHIPPED LOOSE.
- HOUSING:** DIN 41612, SIZE 8 CAVITY.

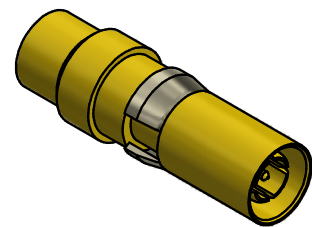

SCALE 2.5 : 1

<table border="1"> <tr> <td>H</td><td>ECN 13788</td><td>6/17/20</td><td>JEM</td></tr> <tr> <td>G</td><td>ECN 10469</td><td>07/20/10</td><td>JEM</td></tr> <tr> <td>F</td><td>ECN 8595</td><td>05/25/07</td><td>HN</td></tr> <tr> <td>E</td><td>ECN 8713</td><td>10/18/06</td><td>JEM</td></tr> <tr> <td>D</td><td>ECN 8469</td><td>04/17/06</td><td>JEM</td></tr> <tr> <td>C</td><td>ECN 7670</td><td>10/18/04</td><td>JEM</td></tr> <tr> <td>REV.</td><td>DESCRIPTION</td><td>DATE</td><td>BY</td></tr> </table>				H	ECN 13788	6/17/20	JEM	G	ECN 10469	07/20/10	JEM	F	ECN 8595	05/25/07	HN	E	ECN 8713	10/18/06	JEM	D	ECN 8469	04/17/06	JEM	C	ECN 7670	10/18/04	JEM	REV.	DESCRIPTION	DATE	BY	<p>THE INFORMATION AND DESIGNS DISCLOSED IN THIS DOCUMENT ARE CONFIDENTIAL AND/OR PROPRIETARY TO THE PHOENIX COMPANY OF CHICAGO INC. AND MAY NOT BE USED FOR MANUFACTURING, REPRODUCED, DISCLOSED TO OTHERS OR FOR ANY OTHER PURPOSE WITHOUT THE EXPRESS WRITTEN CONSENT OF THE PHOENIX COMPANY OF CHICAGO INC.</p>		<p>WARNING - THIS DOCUMENT CONTAINS TECHNICAL DATA WHOSE EXPORT IS RESTRICTED BY THE ARMS EXPORT CONTROL ACT (TITLE 22, U.S.C., SEC 2751, ET. SEQ.) OR THE EXPORT ADMINISTRATION ACT OF 1979, AS AMENDED, TITLE 50, U.S.C., APP 2401 ET SEQ. VIOLATIONS OF THESE EXPORT LAWS ARE SUBJECT TO SEVERE CRIMINAL PENALTIES. DISSEMINATE IN ACCORDANCE WITH PROVISIONS OF DOD DIRECTIVE 5230.25.</p>		<p>Filename: \\Autodesk Inventor Data Base\Assemblies\78 Series\78-1080-0670-CU-Layout for C Sized Drawing.idw</p>		<p>The PHOENIX Company of Chicago, Inc. 22 GREAT HILL RD., NAUGATUCK, CT 06770 WWW.PHOENIXOFCHICAGO.COM PHONE: (800) 323-9562 FAX:(630) 206-1801</p>	
				H	ECN 13788	6/17/20	JEM																																
G	ECN 10469	07/20/10	JEM																																				
F	ECN 8595	05/25/07	HN																																				
E	ECN 8713	10/18/06	JEM																																				
D	ECN 8469	04/17/06	JEM																																				
C	ECN 7670	10/18/04	JEM																																				
REV.	DESCRIPTION	DATE	BY																																				
<p>UNLESS OTHERWISE SPECIFIED, PHOENIX WORKMANSHIP STANDARDS APPLY DIMENSIONS IN INCHES OR (METRIC)</p> <p>DO NOT SCALE PRINTS</p> <p>TOLERANCES ARE: FRACTIONS: ± 1/64 DECIMALS: .XX ± .01 .XXX ± .003 ANGLES: ± 1/2'</p>		<table border="1"> <tr> <th>APPROVALS</th><th>DATE</th></tr> <tr> <td>DRAWN CA</td><td>10/15/20</td></tr> <tr> <td>CHECKED JEM</td><td>10/15/20</td></tr> <tr> <td>QA</td><td></td></tr> <tr> <td>MFG</td><td></td></tr> <tr> <td>ENGINEER JSV</td><td>7/07/96</td></tr> <tr> <td>APPROVED JEM</td><td>7/01/96</td></tr> </table>		APPROVALS	DATE	DRAWN CA	10/15/20	CHECKED JEM	10/15/20	QA		MFG		ENGINEER JSV	7/07/96	APPROVED JEM	7/01/96	<p>TITLE STRAIGHT PLUG, DIRECT SOLDER TERMINATION</p>																					
APPROVALS	DATE																																						
DRAWN CA	10/15/20																																						
CHECKED JEM	10/15/20																																						
QA																																							
MFG																																							
ENGINEER JSV	7/07/96																																						
APPROVED JEM	7/01/96																																						
				<table border="1"> <tr> <td>SIZE B</td> <td>FSCM 58167</td> <td>DWG NO 28-0020-1410</td> <td>REV H</td> <td>PLATING OPT. A, B, C, D</td> </tr> </table>	SIZE B	FSCM 58167	DWG NO 28-0020-1410	REV H	PLATING OPT. A, B, C, D	<p>SCALE</p>		<p>F.S.R. #</p>		<p>SHEET 1 OF 1</p>																									
SIZE B	FSCM 58167	DWG NO 28-0020-1410	REV H	PLATING OPT. A, B, C, D																																			

4

3

2

1