

CATALOG NUMBER	"A" INTERFACE
R007-L43-05-150-R	FULL DETENT
R007-L45-05-150-R	SMOOTH BORE

MATERIAL AND FINISH

HOUSING AND PIN: IRON-NICKEL-COBALT SEALING ALLOY (KOVAR) PER ASTM F 15; GOLD PLATE
 DIELECTRIC: CORNING 7070 GLASS OR EQUIVALENT

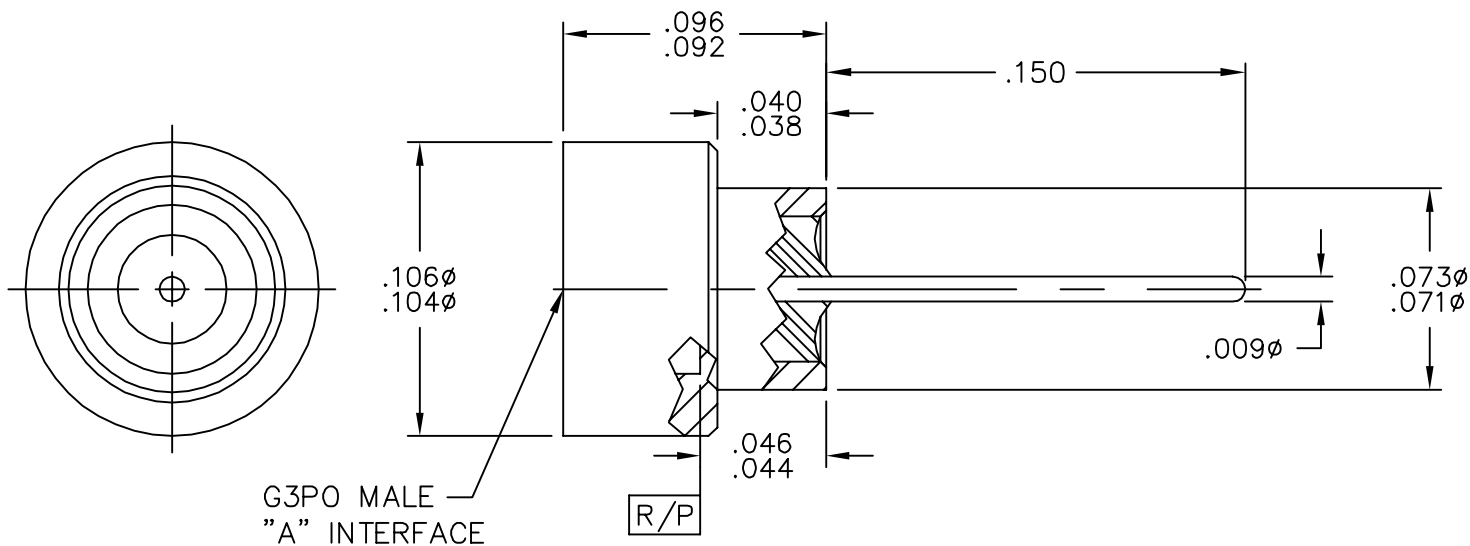
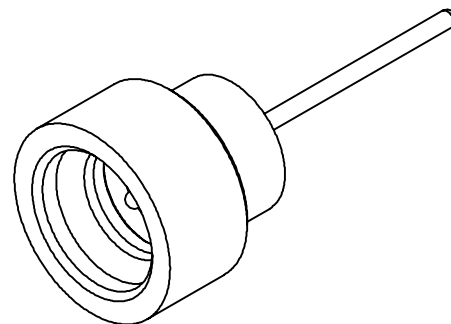

RECOMMENDED FLUSH SHROUD MOUNTING HOLE

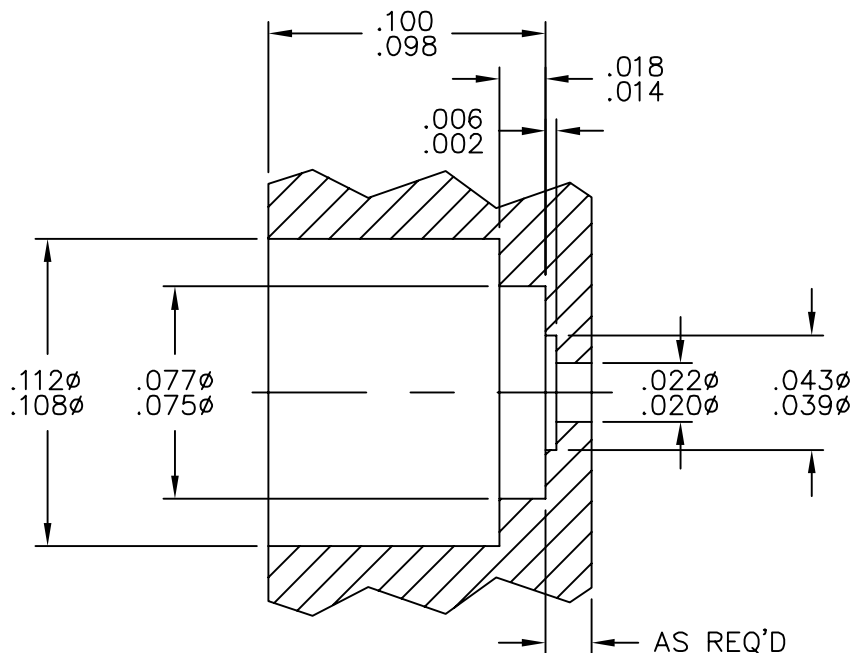

This drawing and any data contained herein is the property of Corning Gilbert Inc., and constitutes and contains proprietary and confidential information. Neither receipt nor possession of this drawing confers or transfers any right to duplicate, use or disclose any information contained herein except as expressly authorized by Corning Gilbert Inc.

G3PO MALE SOLDER-IN
 HERMETIC SHROUD
 (TAB DETENT)

IDENT CODE:

82316

REVISION: 01

Corning Gilbert Inc.

SOURCE FILE: SK-4706

DWG. NO.: OL-R007-L4X-05-150-R

ASSY. PROC.: -